

WIRING DIAGRAM

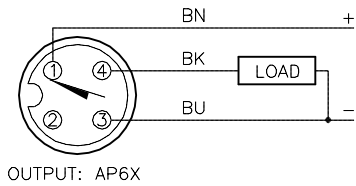

SHORT-CIRCUIT AND OVERLOAD PROTECTED

LOCKNUT LN-M18

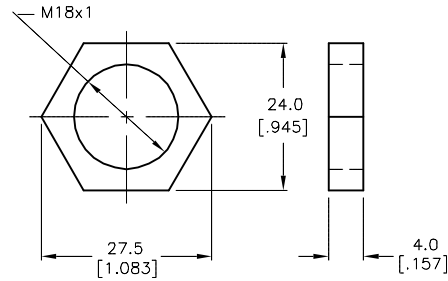

SPECIFICATIONS

RATED OPERATING DISTANCE	5 mm = .197" (NOMINAL)
MOUNTING MODE	FLUSH
HYSTERESIS	3-15%
REPEAT ACCURACY	≤ 2%
TEMPERATURE DRIFT	≤ ± 10%
OPERATING TEMPERATURE	-25°C to +70°C (-13°F to +158°F)
RATED OPERATIONAL VOLTAGE	10-30 VDC
RESIDUAL RIPPLE	≤ 10%
DC RATED OPERATIONAL CURRENT	≤ 200 mA
NO-LOAD CURRENT	≤ 15 mA
RESIDUAL CURRENT	≤ 0.1 mA
RATED INSULATION VOLTAGE	≤ 0.5 kV
SHORT-CIRCUIT PROTECTED	YES
MAX. VOLTAGE DROP	≤ 1.8 V
REVERSE POLARITY PROTECTION	INCORPORATED
WIRE-BREAK PROTECTION	INCORPORATED
OUTPUT FUNCTION	3-WIRE, NORMALLY OPEN, PNP
MAX. SWITCHING FREQUENCY	≤ 0.5 kHz
HOUSING MATERIAL	METAL, BRASS, CHROME-PLATED
ACTIVE FACE MATERIAL	PLASTIC, PA12-GF30
END CAP MATERIAL	PLASTIC, EPTR
CABLE	∅5.2, Lifyy,PVC
SHOCK	30 g, 11 ms
VIBRATION	55 Hz, 1 mm AMPLITUDE (IN ALL 3 PLANES)
DEGREE OF PROTECTION	IP67
SWITCHING STATUS INDICATION	LED, YELLOW

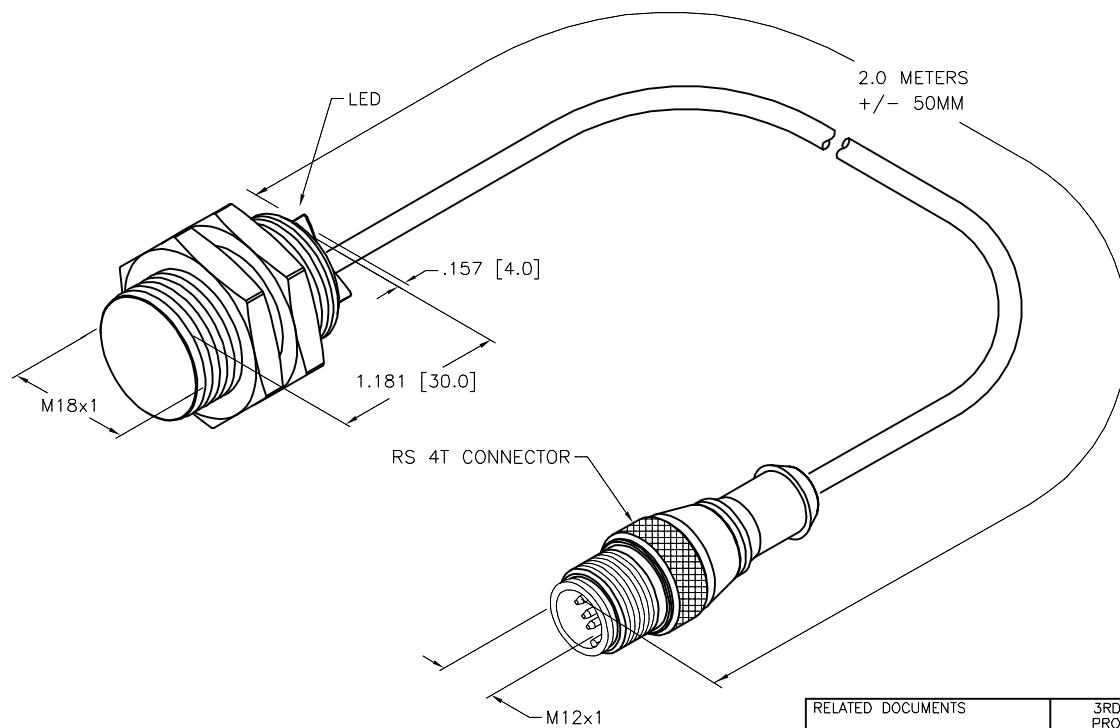

SOURCE DRAWING - FOR REFERENCE ONLY

RELATED DOCUMENTS 1. 2. 3. 4.	3RD ANGLE PROJECTION 	THIS DRAWING IS CONFIDENTIAL AND THE PROPERTY OF TURCK INC. USE OF THIS DOCUMENT WITHOUT WRITTEN PERMISSION IS PROHIBITED.		3000 CAMPUS DRIVE MINNEAPOLIS, MN 55441 1-800-544-7769 (763) 553-7300 (763) 553-0708 fax turck.com	
	MATERIAL	DRFT RDS APVD	DATE 06/24/10 SCALE 1=1.0	DESCRIPTION BI 5-G18K-AP6X-2M-RS 4T	
FINISH	ALL DIMENSIONS DISPLAYED ON THIS DRAWING ARE FOR REFERENCE ONLY CONTACT TURCK FOR MORE INFORMATION	UNIT OF MEASUREMENT INCH [MILLIMETER]		IDENTIFICATION NO. T46704001	REV B
DO NOT SCALE THIS DRAWING		FILE: T46704001		SHEET 1 OF 1	

B	ADD TOLERANCE TO OVERALL LENGTH	KMY	01/27/14	44687
REV	DESCRIPTION	BY	DATE	ECO NO.