

**SPECIFICATIONS**

CONTACT CARRIER MATERIAL	NYLON
MOLDED MATERIAL/COLOR	TPU/BLACK
CONTACT MATERIAL/PLATING	BRASS/GOLD
RECEPTACLE HOUSING MAT'L/PLATING	BRASS/NICKEL
RATED CURRENT [A]	0.5 A
RATED VOLTAGE [V]	50 VAC/60 VDC
OUTER CABLE JACKET MATERIAL/COLOR	TPU/BLACK
CONDUCTOR INSULATION MATERIAL	PE
NUMBER OF CONDUCTORS [AWG]	8x26 AWG, STRANDED
SHIELDING	ALUM.-POLYESTER FOIL & T-C BRAIDED
TRANSMISSION CHARACTERISTICS	CAT6
TEMPERATURE RANGE	-30°C to +90°C (-22°F to +194°F)
PROTECTION CLASS	MEETS IEC IP67, IP69K
PANEL THICKNESS	5.0 [0.197] MAX.

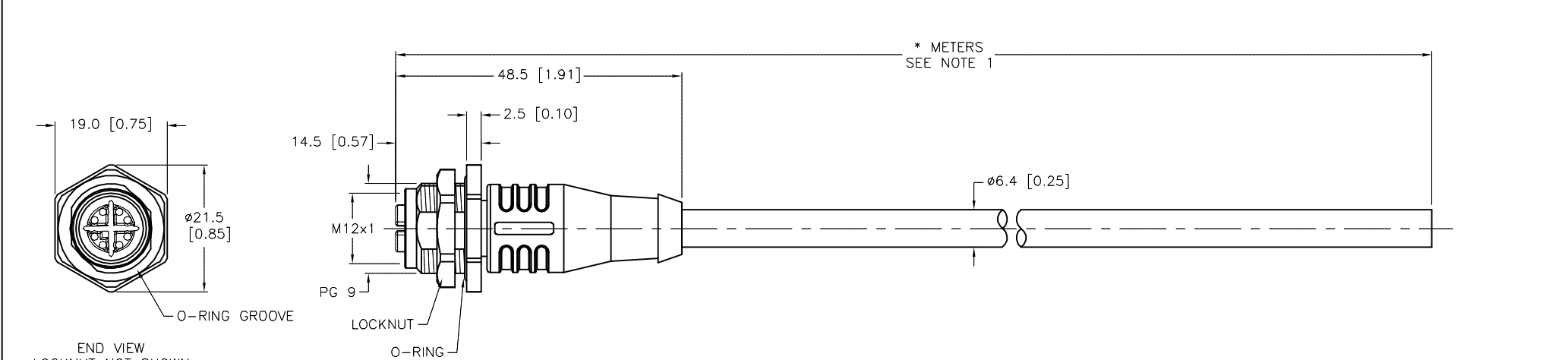

I.D. NUMBER	DESCRIPTION	CABLE LENGTH
U-85529	FKFDX 862BK-0.3M	0.3 METERS
U-84866	FKFDX 862BK-1M	1.0 METER
U2-23125	FKFDX 862BK-2M	2.0 METERS
U2-23127	FKFDX 862BK-5M	5.0 METERS
U2-23126	FKFDX 862BK-10M	10.0 METERS

CABLE LENGTH	TOLERANCE*
ALL LENGTHS	+ 4% (OR 50mm) OF LENGTH - 0% (OR 0mm) OF LENGTH WHICHEVER IS GREATER
STRIP LENGTH	TOLERANCE*
0-7mm	±0.5mm
8-29mm	±1.0mm
30-49mm	±2.0mm
50-69mm	±3.0mm
70-100mm	±4.0mm
OVER 100mm	±5.0mm

\* UNLESS OTHERWISE SPECIFIED

SOURCE DRAWING - FOR REFERENCE ONLY

NOTES:  
1. "\*" INDICATES CABLE LENGTH IN METERS. CONTACT TURCK TO ORDER SPECIFIC LENGTHS.

RELATED DOCUMENTS 1. 2. 3. 4.	3RD ANGLE PROJECTION 	THIS DRAWING IS CONFIDENTIAL AND THE PROPERTY OF TURCK INC. USE OF THIS DOCUMENT WITHOUT WRITTEN PERMISSION IS PROHIBITED.		<b>TURCK INC</b> High Technology Sensors and Automation Controls 3000 CAMPUS DRIVE MINNEAPOLIS, MN 55441 1-800-544-7769 (763) 553-7300 (763) 553-0708 fax turck.com	
		DRFT RDS	DATE 05/08/14	DESCRIPTION FKFDX 862BK-*M	
MATERIAL	ALL DIMENSIONS DISPLAYED ON THIS DRAWING ARE FOR REFERENCE ONLY	APVD L.S.	SCALE 1=1.0	IDENTIFICATION NO.	
FINISH		UNIT OF MEASUREMENT <b>MILLIMETER [ INCH ]</b>		REV C	
C	ADD U-85529 TO CHART	RDS	06/22/15	50434	
REV	DESCRIPTION	BY	DATE	ECO NO.	DO NOT SCALE THIS DRAWING
					FILE: 777035227
					SHEET 1 OF 1

C	ADD U-85529 TO CHART	RDS	06/22/15	50434
REV	DESCRIPTION	BY	DATE	ECO NO.