

SPECIFICATIONS

|                           |                                   |
|---------------------------|-----------------------------------|
| CAP MATERIAL/FINISH       | ALUMINUM ALLOY/OLIVE DRAB PLATING |
| CABLE AND EYELET MATERIAL | SST                               |

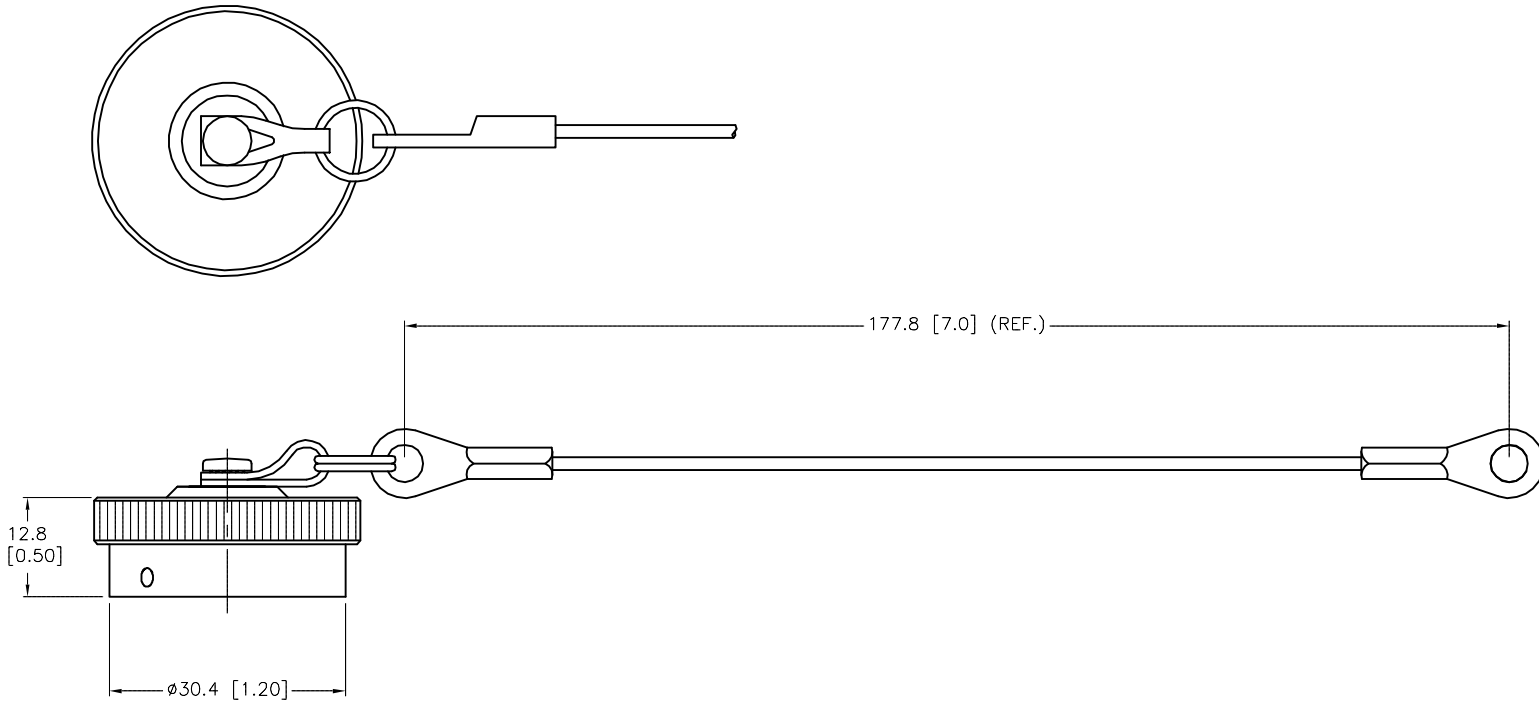

SOURCE DRAWING - FOR REFERENCE ONLY

NOTES:

1. ALL DIMENSIONS ARE REFERENCE.

|                    |  |   |  |                                     |   |               |
|--------------------|--|---|--|-------------------------------------|---|---------------|
| RELATED DOCUMENTS  |  | 3RD ANGLE PROJECTION  | THIS DRAWING IS CONFIDENTIAL AND THE PROPERTY OF TURCK INC. USE OF THIS DOCUMENT WITHOUT WRITTEN PERMISSION IS PROHIBITED. |                                     | <b>TURCK INC</b><br><i>High Technology Sensors and Automation Controls</i><br>3000 CAMPUS DRIVE<br>MINNEAPOLIS, MN 55441<br>1-800-544-7769<br>(763) 553-7300<br>(763) 553-0708 fax<br>turck.com |               |
| 1.                 |  |   | DRFT   | RDS                                 | DATE  | 01/16/14      |
| 2.                 |  |   | APVD   | J.B.                                | SCALE   | 1=1.0         |
| 3.                 |  | ALL DIMENSIONS DISPLAYED ON THIS DRAWING ARE FOR REFERENCE ONLY | UNIT OF MEASUREMENT  |                                     |   | DESCRIPTION   |
| 4.                 |  |   | MILLIMETER [ INCH ]  |                                     |   | MS 3110-16-CC |
| MATERIAL           |  | CONTACT TURCK FOR MORE INFORMATION                              | IDENTIFICATION NO.   |                                     |   | REV           |
| SEE SPECIFICATIONS |  |   | U-59650  |                                     |   | A             |
| FINISH             |  | DO NOT SCALE THIS DRAWING                                       |  |                                     | FILE: U-59650   | SHEET 1 OF 1  |
| SEE SPECIFICATIONS |  | DRFT RDS DATE 01/16/14<br>APVD J.B. SCALE 1=1.0                 |  | IDENTIFICATION NO. U-59650<br>REV A |   |               |

|     |                 |     |          |         |
|-----|-----------------|-----|----------|---------|
| A   | DRAWING RELEASE | RDS | 01/16/14 |         |
| REV | DESCRIPTION     | BY  | DATE     | ECO NO. |