

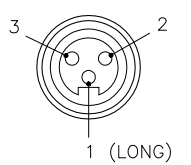

MALE END VIEW (P1)	FEMALE END VIEW (J1-J2)	WIRING DIAGRAM	SPECIFICATIONS																	
			<table border="1"> <tr><td>MOLDED BODY MATERIAL/COLOR</td><td>NYLON/BLACK</td></tr> <tr><td>CONTACT CARRIER MATERIAL/COLOR</td><td>TPU/BLACK</td></tr> <tr><td>CONTACT MATERIAL/PLATING</td><td>BRASS/GOLD</td></tr> <tr><td>COUPLING NUT MATERIAL/PLATING</td><td>BRASS/NICKEL</td></tr> <tr><td>RATED CURRENT [A]</td><td>9.0 A</td></tr> <tr><td>RATED VOLTAGE [V]</td><td>600 V</td></tr> <tr><td>TEMPERATURE RANGE</td><td>-40°C TO +105°C (-40°F TO +221°F)</td></tr> <tr><td>PROTECTION CLASS</td><td>MEETS NEMA 1,3,4,6P AND IEC IP67</td></tr> </table>	MOLDED BODY MATERIAL/COLOR	NYLON/BLACK	CONTACT CARRIER MATERIAL/COLOR	TPU/BLACK	CONTACT MATERIAL/PLATING	BRASS/GOLD	COUPLING NUT MATERIAL/PLATING	BRASS/NICKEL	RATED CURRENT [A]	9.0 A	RATED VOLTAGE [V]	600 V	TEMPERATURE RANGE	-40°C TO +105°C (-40°F TO +221°F)	PROTECTION CLASS	MEETS NEMA 1,3,4,6P AND IEC IP67	
MOLDED BODY MATERIAL/COLOR	NYLON/BLACK																			
CONTACT CARRIER MATERIAL/COLOR	TPU/BLACK																			
CONTACT MATERIAL/PLATING	BRASS/GOLD																			
COUPLING NUT MATERIAL/PLATING	BRASS/NICKEL																			
RATED CURRENT [A]	9.0 A																			
RATED VOLTAGE [V]	600 V																			
TEMPERATURE RANGE	-40°C TO +105°C (-40°F TO +221°F)																			
PROTECTION CLASS	MEETS NEMA 1,3,4,6P AND IEC IP67																			
																				

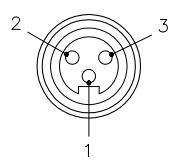
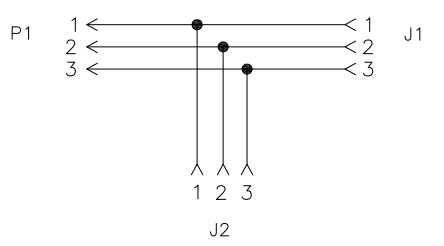

SOURCE DRAWING - FOR REFERENCE ONLY

RELATED DOCUMENTS 1. 2. 3. 4.	3RD ANGLE PROJECTION 	THIS DRAWING IS PROPERTY OF TURCK INC. USE OF THIS DOCUMENT WITHOUT WRITTEN PERMISSION IS PROHIBITED.	<div style="text-align: right;"> <p>3000 CAMPUS DRIVE MINNEAPOLIS, MN 55441 1-800-544-7769 (763) 553-7300 (763) 553-0708 fax turck.com</p> </div>	
MATERIAL SEE SPECIFICATIONS	ALL DIMENSIONS DISPLAYED ON THIS DRAWING ARE FOR REFERENCE ONLY	DRFT RDS DATE 05/06/09 DSGN SCALE 1=1.5	DESCRIPTION MT-RSM-2RKM 30	
FINISH SEE SPECIFICATIONS	CONTACT TURCK FOR MORE INFORMATION	UNIT OF MEASUREMENT MILLIMETERS IDENTIFICATION NO. U2-15457 REV B DO NOT SCALE THIS DRAWING FILE: U2-15457 SHEET 1 OF 1		

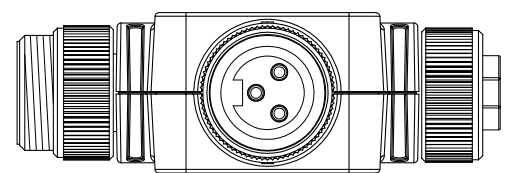
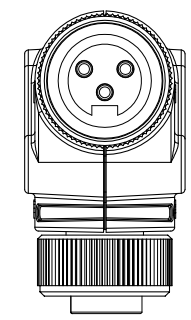
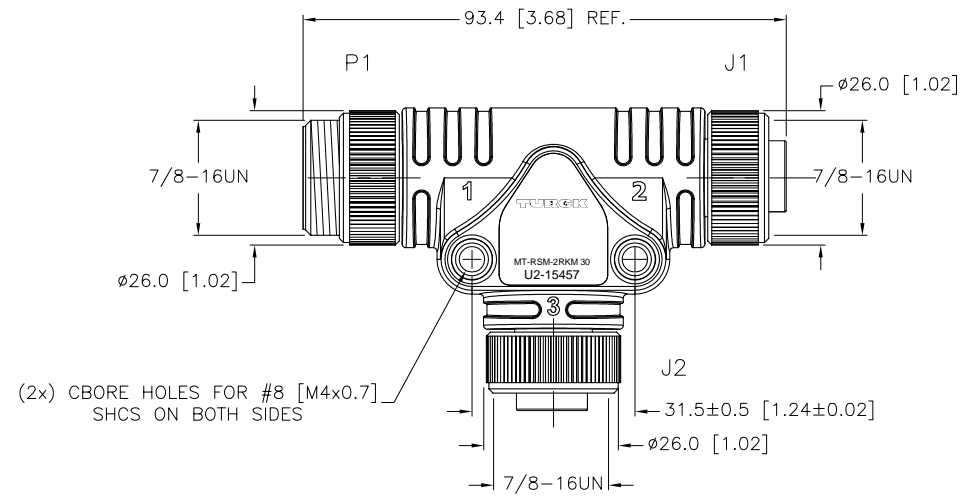
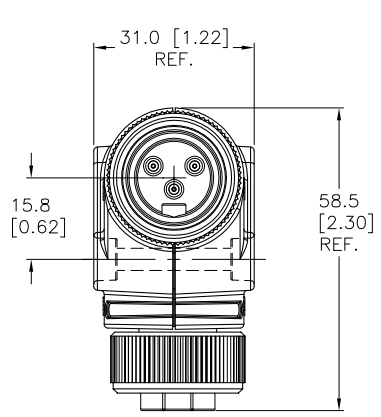
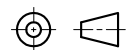
B	DRAWING PROCESSED AS PART OF ECO 33971	CBM	04/07/11	33971
REV	DESCRIPTION	BY	DATE	ECO NO.