

Solid State Relays PCB, 1-Phase DCS Type RP 530 ...-.-0

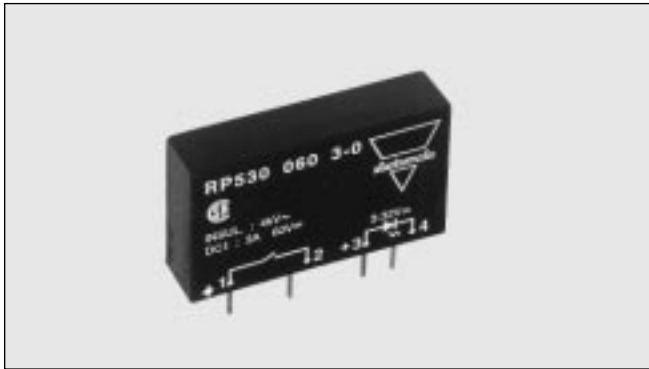

- DC Solid State Relay for PCB mounting
- Rated operational current: 1 and 3 ADC
- Operational voltage range: Up to 350 VDC
- Input range: 3 to 32 VDC
- Insulation: OPTO (input-output) 4000 VACrms

Product Description

The DC switching relay for PCB mounting is used in applications where there is a need for fast switching of small DC loads with a high input/output insulation of more than 4000 VACrms. The DC switching transistor relay always switches on and off in accordance with the applied control voltage.

Ordering Key

RP 530 060-3-0

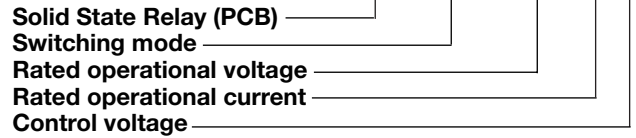

Type Selection

Switching mode	Rated operational voltage	Rated operational current	Control voltage
530: DC switching	060: 60 VDC 200: 200 VDC 350: 350 VDC	1: 1 ADC 3: 3 ADC	0: 3 to 32 VDC

Selection Guide

Rated operational voltage	Control voltage	Rated operational current 1 ADC	3 ADC
60 VDC	3 to 32 VDC		RP 530 060-3-0
200 VDC	3 to 32 VDC	RP 530 200-1-0	
350 VDC	3 to 32 VDC	RP 530 350-1-0	

General Specifications

	RP 530 060-3-0	RP 530 200-1-0	RP 530 350-1-0
Operational voltage range	3 to 60 VDC	3 to 200 VDC	3 to 350 VDC
Off-state blocking voltage	≥ 60 VDC	≥ 200 VDC	≥ 350 VDC
Approval	CSA	CSA	CSA
CE-marking	Yes	Yes	Yes

Input Specifications

	RP 530 060-3-0	RP 530 200-1-0 RP 530 350-1-0
Control voltage range	3 to 32 VDC	3 to 32 VDC
Pick-up voltage	≤ 3 VDC	≤ 3 VDC
Drop-out voltage	≥ 1 VDC	≥ 1 VDC
Reverse voltage	≤ 6 VDC	≤ 6 VDC
Activating frequency	≤ 100 Hz	≤ 100 Hz
Input impedance	1 kΩ	1 kΩ
Response time pick-up @ V _{in} ≥ 5 V	≤ 100 μs	≤ 100 μs
Response time drop-out	≤ 1 ms	≤ 1 ms
Control voltage rise and fall time	No limit	≤ 100 ms

Output Specifications

	RP 530 060-3-0	RP 530 200-1-0	RP 530 350-1-0
Rated operational current DC 1	3 A	1 A	1 A
DC 5	2 A	0.5 A	0.5 A
DC 13	3 A	1 A	1 A
Minimum operational current	1 mA	1 mA	1 mA
Rep. overload current t=1 s	5 A	2 A	2 A
Off-state leakage current @ rated voltage	≤ 1 mA	≤ 1 mA	≤ 1 mA
On-state voltage drop @ rated current	≤ 1.5 V	≤ 1.5 V	≤ 1.5 V

Thermal Specifications

Operating temperature	-20° to +70°C (-4° to +158°F)
Storage temperature	-40° to +100°C (-40° to +212°F)
Junction temperature	≤ 125°C (≤ 257°F)
R _{th} junction to case	≤ 15 K/W
R _{th} junction to ambient	≤ 22.5 K/W

Insulation Input - Output

Rated insulation voltage	≥ 4000 VACrms
Insulation resistance	≥ 10 ¹⁰ Ω
Insulation capacitance	≤ 8 pF

Wiring Diagrams

RP 530 060-3-0

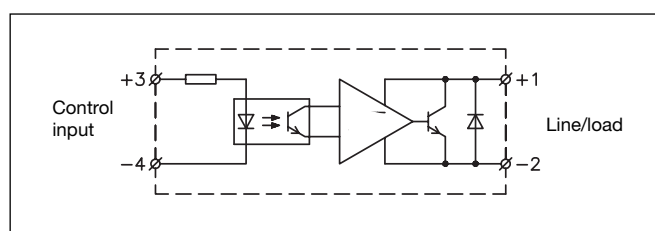

RP 530 200-1-0
RP 530 350-1-0

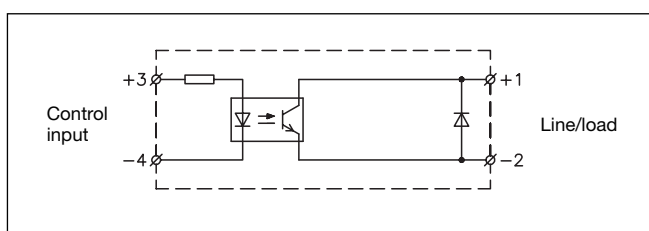

Functional Diagrams

RP 530 060-3-0

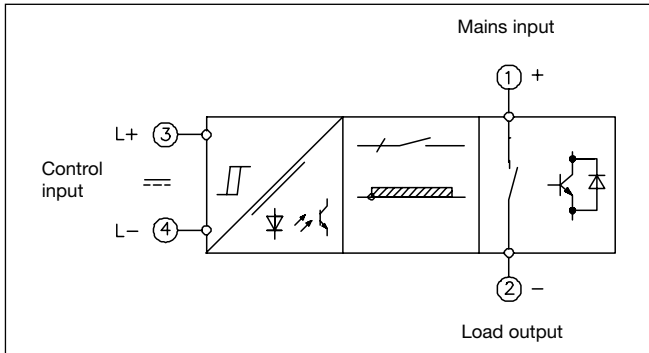

RP 530 200-1-0

RP 530 350-1-0

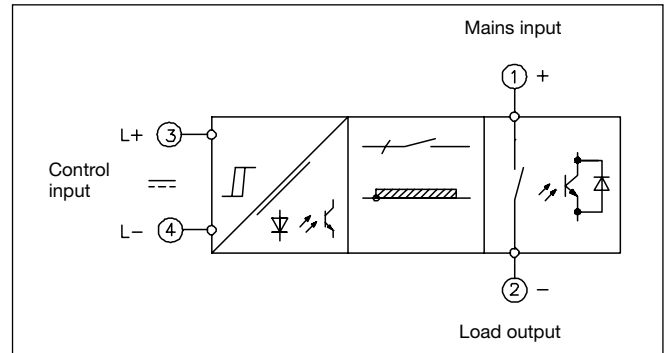

Applications

Wiring examples:

High power switching

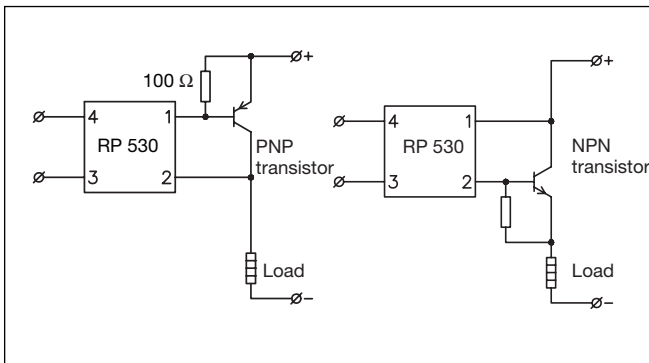

Inductive load

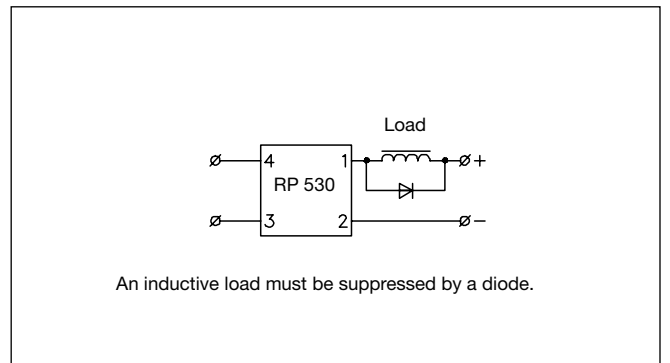

Dimensions

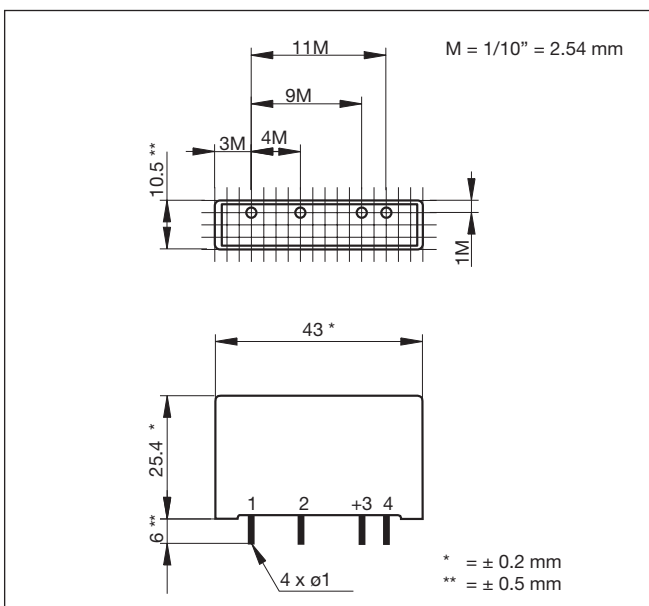

Housing Specifications

Weight	Approx. 20 g
Housing material	Noryl GFN 1, black
Terminals	Phos. bronze, tin-plated
Potting compound	Polyurethane

Derating Curve

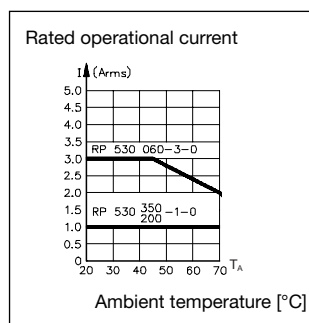

Accessories

Fuses
For further information refer to "General Accessories".