

Part Number CO27VH15DE-02-10.000
HCMOS Output



Applications

- Base Stations
- RF Sources

Features

- High Stability
- Excellent Phase Noise
- AT-Cut Crystal

FREQUENCY STABILITIES	MIN	TYP	MAX	UNITS	CONDITIONS
Frequency vs Operating Temp	-200		+200	PPB	-20° to +80°C (referenced to 25°C)
Frequency vs 5 years aging	-500		+500	PPB	
Frequency vs 10 years aging	-700		+700	PPB	-20° to +80°C
Warm-up Time to within ±200ppb			3.00	Minutes	@ +25°C

Supply Voltage / Current	MIN	TYP	MAX	UNITS	CONDITIONS
Supply Voltage	+14	+15	+16	VDC	
Supply Current			500	mA	During Warm-up
			110	mA	Steady State

SINEWAVE OUTPUT	MIN	TYP	MAX	UNITS	CONDITIONS
Signal Level (Voh)	4.5			VDC	
Signal Level (Vol)			0.5	VDC	
Load	45		55	%	@ (Voh-Vol)/2
Load		15		pF	

PN: CO27VH15DE-02-10.000 Rev. C

Part Number CO27VH15DE-02-10.000
 SineWave Output

FREQUENCY TUNING	MIN	TYP	MAX	UNITS	CONDITIONS
Tuning Range	±1		±1.5	PPM	Over Control Range
Control Range	0	5	10	VDC	
Input Resistance	50K			Ω	
Slope	POSITIVE				
Linearity			10	%	
Setability @ MHz	4	5	6	VDC	

OUTPUT CHARACTERISTICS	MIN	TYP	MAX	UNITS	CONDITIONS
Phase Noise			-102	dBc/Hz	@ 10Hz Offset
			-132		@ 100Hz Offset
			-150		@ 1KHz Offset
			-152		@ 10KHz Offset
Short Term Stability		2x10 ⁻¹¹		Sec	Allen Variance @ 1 Sec
Spurious			-93	dBc	Within 100Hz to 3MHz from Carrier

ABSOLUTE MAXIMUM RATING	MIN	TYP	MAX	UNITS	CONDITIONS
Supply Voltage			20	VDC	
Storage Temperature	-45		+90	°C	
Operable Temperature	-20		+80	°C	
Load			50	pF	

ENVIRONMENTAL CONDITIONS	
SHOCK	IEC 68-2-27 (Test Ea) 30G, 10mSec, Half Sine
VIBRATION	IEC 68-2-6 (Test Fc) 0.35mm, 10G, 5-500Hz, 6 cycles/axis
THERMAL SHOCK	IEC 68-2-14 (Test Na) 30 min. in each extreme temperature
HUMIDITY	MIL-STD-202 method 106D

PN: CO27VH15DE-02-10.000 Rev. C

Part Number CO27VH15DE-02-10.000
SineWave Output

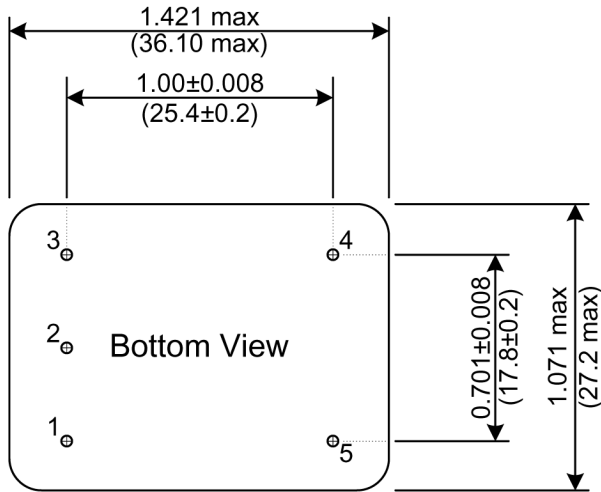

Pin	Function
1	Control Voltage
2	No Connect
3	Supply Voltage
4	RF Output
5	Case Ground

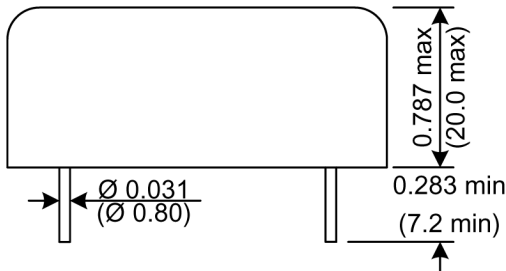

Unless otherwise specified,
dimensions are in: $\frac{IN}{(mm)}$

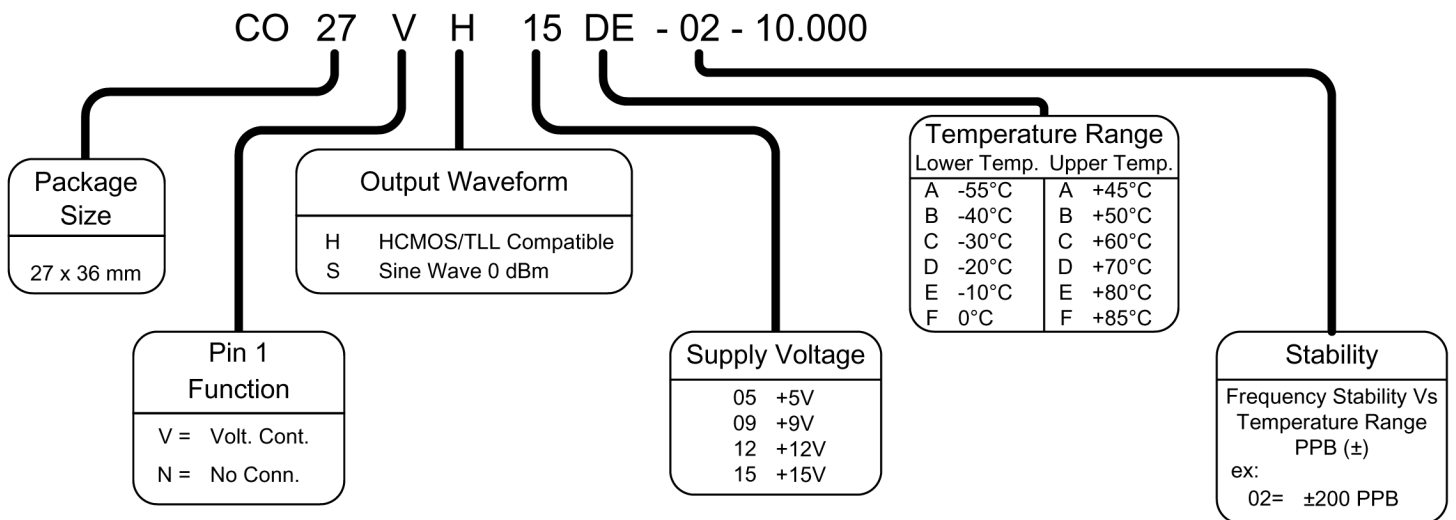

PN: CO27VH15DE-02-10.000 Rev. C