

WIRING DIAGRAM

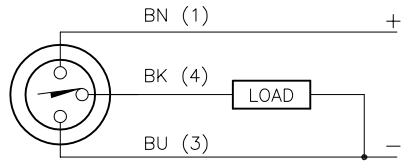

OUTPUT: AP6X

SHORT-CIRCUIT AND OVERLOAD PROTECTED

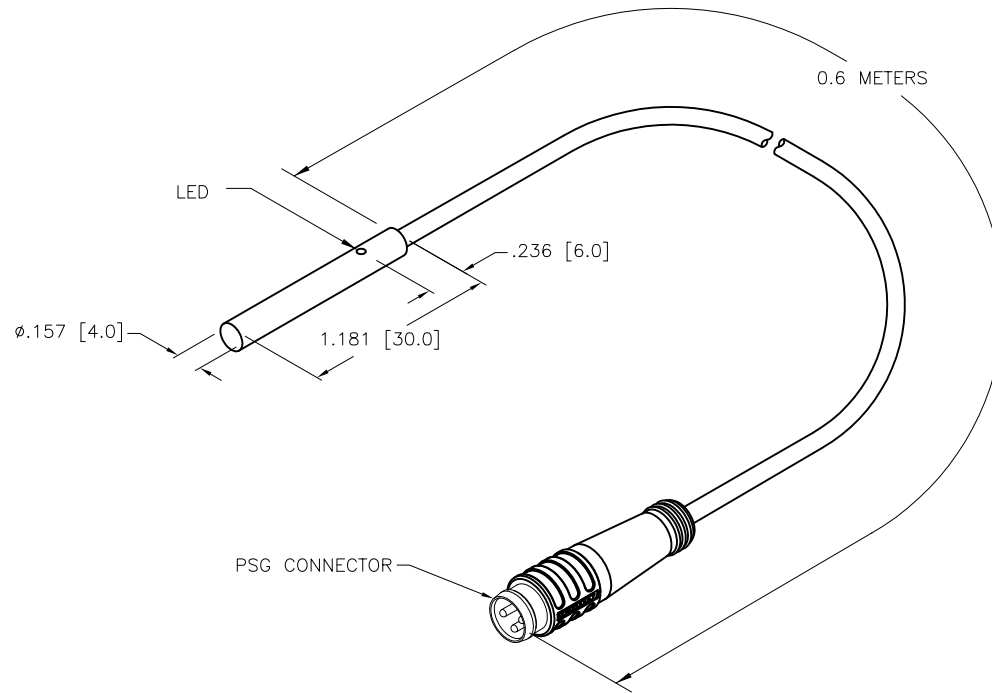

SPECIFICATIONS

RATED OPERATING DISTANCE	1mm = .039"
MOUNTING MODE	FLUSH
MIN. REPEAT ACCURACY	≤ 2%
TEMPERATURE DRIFT	≤ ±10%
HYSTERESIS (SWITCHING DISTANCE)	3-15%
OPERATING TEMPERATURE	-25°C to +70°C (-13°F to +158°F)
RATED OPERATIONAL VOLTAGE	10-30 VDC
MAX. RIPPLE	≤ 10%
DC RATED OPERATIONAL CURRENT	≤ 100 mA
NO-LOAD CURRENT	≤ 15 mA
MAX. OFF-STATE CURRENT	≤ 0.1 mA
RATED INSULATION VOLTAGE	≤ 0.5 kV
SHORT-CIRCUIT PROTECTION	INCORPORATED
MAX. VOLTAGE DROP	≤ 1.8 V
WIRE BREAKAGE PROTECTION	INCORPORATED
REVERSE POLARITY PROTECTION	INCORPORATED
OUTPUT FUNCTION	3-WIRE, NORMALLY OPEN, PNP
MAX. SWITCHING FREQUENCY	≤ 3 kHz
HOUSING MATERIAL	METAL, A4 1.4404 (AISI 316L)
ACTIVE FACE	PLASTIC, PA12-GF20
END CAP	PLASTIC, TROGAMID T
CABLE	ø3.0, LiFYY-11Y, TPU
VIBRATION RESISTANCE	55 Hz, 1 mm AMPLITUDE (IN ALL 3 PLANES)
SHOCK RESISTANCE	30 g, 11 ms
DEGREE OF PROTECTION	IP67
SWITCHING STATUS INDICATION	LED, YELLOW

SOURCE DRAWING - FOR REFERENCE ONLY

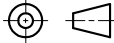
RELATED DOCUMENTS		3RD ANGLE PROJECTION		THIS DRAWING IS CONFIDENTIAL AND THE PROPERTY OF TURCK INC. USE OF THIS DOCUMENT WITHOUT WRITTEN PERMISSION IS PROHIBITED.		 3000 CAMPUS DRIVE MINNEAPOLIS, MN 55441 1-800-544-7769 (763) 553-7300 (763) 553-0708 fax turck.com	
1. 2. 3. 4.				DRFT	KMY	DATE	02/15/12
MATERIAL		ALL DIMENSIONS DISPLAYED ON THIS DRAWING ARE FOR REFERENCE ONLY		APVD	A.F.	SCALE	1=1.0
FINISH		CONTACT TURCK FOR MORE INFORMATION		UNIT OF MEASUREMENT		DESCRIPTION	
				INCH [ MILLIMETER ]		BI 1-EH04-AP6X-0.6M-PSG 3	
				DO NOT SCALE THIS DRAWING		IDENTIFICATION NO.	
						S4609540-000	
						REV	
						A	
A		DRAWING RELEASE		KMY		02/15/12	
REV		DESCRIPTION		BY		DATE	
						ECO NO.	
						FILE: S4609540-000	
						SHEET 1 OF 1	

A	DRAWING RELEASE	KMY	02/15/12	
REV	DESCRIPTION	BY	DATE	ECO NO.