

BOS 11K-NA-RR10-02 BOS012N

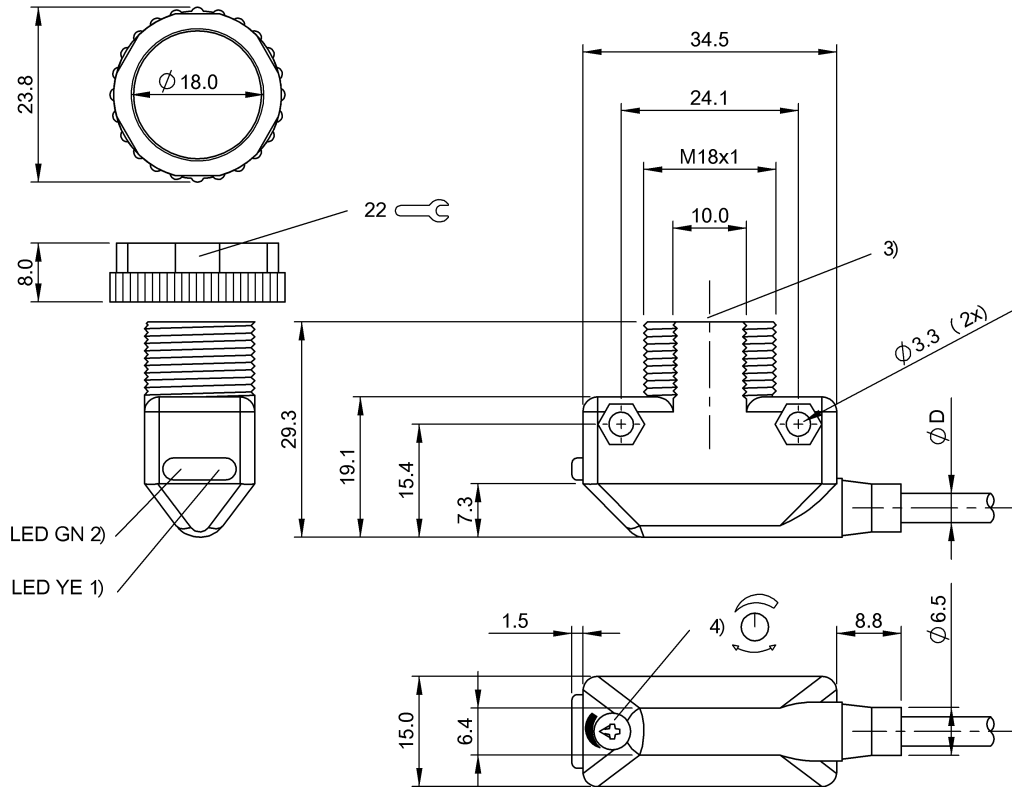

1) Output function 2) Operating voltage 3) Optical axis 4) Sn



Display/Operation

Adjuster	Potentiometer 270° (1x)
Setting	Sensitivity (Sn)

Ready delay t_v max.	200 ms
Residual current I_r max.	100 μ A
Switching frequency	500 Hz
Turn-off delay t_{off} max.	1 ms
Turn-on delay t_{on} max.	1 ms
Voltage drop U_d max. at I_e	2 V

Electrical connection

Cable diameter D	6.50 mm
Cable length	2 m
Conductor cross-section	0.13 mm ²
Connection type	Cable, 2.00 m, PVC
Number of conductors	4
Polarity reversal protected	yes
Short-circuit protection	yes

Environmental conditions

Ambient temperature	-20...55 °C
Protection class	II
Protection type IEC 60529	IP67
Reference reflector	BOS R-1

Electrical data

MTTF (40 °C)	542 a
No-load current I_0 max. at U_e	25 mA
Operating voltage U_b	10...30 VDC
Protected against miswiring	yes
Rated insulation voltage U_i	75 V DC
Rated operating current I_e DC	100 mA
Rated operating voltage U_e DC	24 V

Functional safety

Diagnostic coverage	0.0 %
Functional safety	no

General data

Approval/Conformity	CE cULus
Basic standard	IEC 60947-5-2
Series	11K

BOS 11K-NA-RR10-02 BOS012N

Style	Square Connection 90°
Trademark	Global

Wave length 950 nm

Material

Housing material	ABS
Material jacket	PVC
Material sensing surface	PMMA

Mechanical data

Blind zone	50 mm
Dimension	15 x 44.8 x 29.3 mm
Fastening detail	Screw M3 Nut M18x1

Optical data

Ambient light max.	10000 Lux
Beam characteristic	Divergent
Light type	Red light
Polarizing filter	no
Principle of optical operation	Retroreflective sensor

Output/Interface

Switching output	NPN Normally closed (NC) NPN Normally open (NO)
------------------	--

Range/Distance

Measuring range	0...6.5 m
Range	0...6.5 m
Rated operating distance S_n	6.5 m, Adjustable
Ripple max. (% of U_e)	10 %

Remarks

Order accessories separately.

For additional information, refer to user's guide.

Actuation object (target): gray card, 200 x 200, 90 % remission, lateral approach, approach direction vertical to lens axis plane.

The sensor is functional again after the overload has been eliminated.

For further information on MTTF/B10d, please refer to the MTTF / B10d Certificate.

Specification of the MTTF value and the B10d value do not represent any binding quality and/or life expectancy guarantees.

Wiring Diagram

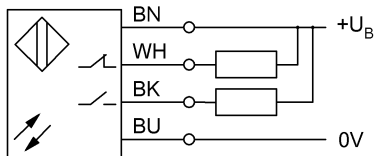

Symbols for Optoelectronic Sensors

