

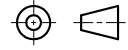

CABLE LENGTH	TOLERANCE
ALL LENGTHS	+ 4% (OR 50mm) OF LENGTH - 0% (OR 0mm) OF LENGTH WHICHEVER IS GREATER
STRIP LENGTH	TOLERANCE
0-7mm	±0.5mm
8-29mm	±1.0mm
30-49mm	±2.0mm
50-69mm	±3.0mm
70-100mm	±4.0mm
OVER 100mm	±5.0mm

- NOTES:
- "*" INDICATES CABLE LENGTH IN METERS. CONTACT TURCK TO ORDER SPECIFIC LENGTHS.
 - "/S90" DESIGNATES THERMOPLASTIC POLYURETHANE (TPU) CABLE.
 - "/S1572" DESIGNATES CUSTOM WIRING.

SOURCE DRAWING - FOR REFERENCE ONLY

RELATED DOCUMENTS 1. 2. 3. 4.	3RD ANGLE PROJECTION 	THIS DRAWING IS CONFIDENTIAL AND THE PROPERTY OF TURCK INC. USE OF THIS DOCUMENT WITHOUT WRITTEN PERMISSION IS PROHIBITED.	 High Technology Sensors and Automation Controls	3000 CAMPUS DRIVE MINNEAPOLIS, MN 55441 1-800-544-7769 (763) 553-7300 (763) 553-0708 fax turck.com
MATERIAL	SEE SPECIFICATIONS	DRFT CK	DATE 04/11/11	DESCRIPTION KB 3T-*--PSG 3/S90/S1572
FINISH	SEE SPECIFICATIONS	DSGN	SCALE 1=1.0	IDENTIFICATION NO.
	CONTACT TURCK FOR MORE INFORMATION	UNIT OF MEASUREMENT MILLIMETER [INCH]		REV B
		DO NOT SCALE THIS DRAWING		FILE: 777015521
B	UPDATE CABLE OD	CK	08/10/11	35981
REV	DESCRIPTION	BY	DATE	ECO NO.