

FEMALE END VIEW

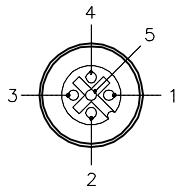

- 1 = BROWN
- 2 = WHITE
- 3 = BLUE
- 4 = BLACK
- 5 = GREY



TYPICAL PANEL CUTOUT

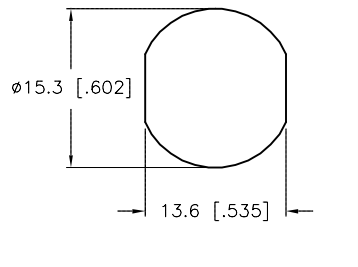

SPECIFICATIONS

| | |
|----------------------------------|-----------------------------------|
| CONTACT CARRIER MATERIAL | NYLON OR TPU |
| CONTACT MATERIAL/PLATING | BRASS/GOLD |
| HOUSING/LOCKNUT MATERIAL/PLATING | BRASS/NICKEL |
| O-RING MATERIAL | NITRILE (BUNA-N) |
| RATED CURRENT [A] | 4.0 A |
| RATED VOLTAGE [V] | 250 V |
| CONDUCTOR INSULATION MATERIAL | PVC |
| NUMBER OF CONDUCTORS [AWG] | 5x18 AWG |
| TEMPERATURE RANGE | -40°C to +105°C (-40°F to +221°F) |
| PROTECTION CLASS | MEETS NEMA 1,3,4,6P AND IEC IP68 |
| MAX. PANEL THICKNESS | 3.0 [0.12] |

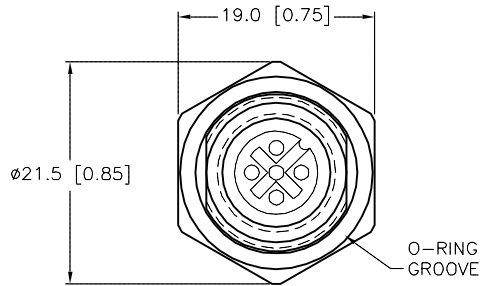

END VIEW
LOCKNUT NOT SHOWN

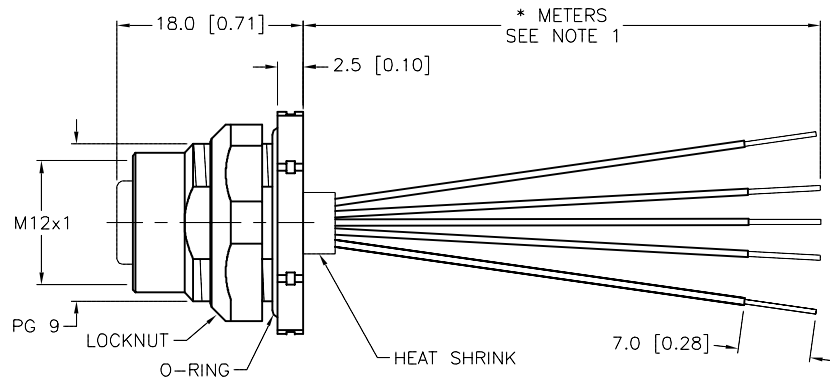

| CABLE LENGTH | TOLERANCE* |
|--------------|---|
| ALL LENGTHS | + 4% (OR 50mm) OF LENGTH - 0% (OR 0mm) OF LENGTH WHICHEVER IS GREATER |
| STRIP LENGTH | TOLERANCE* |
| 0-7mm | ±0.5mm |
| 8-29mm | ±1.0mm |
| 30-49mm | ±2.0mm |
| 50-69mm | ±3.0mm |
| 70-100mm | ±4.0mm |
| OVER 100mm | ±5.0mm |

* UNLESS OTHERWISE SPECIFIED

NOTES:

- "*" INDICATES LEAD LENGTH IN METERS. CONTACT TURCK TO ORDER SPECIFIC LENGTHS.
- "/S613" DESIGNATES 18 AWG CONDUCTORS.

SOURCE DRAWING - FOR REFERENCE ONLY

| | | | | | | | |
|-------------------|--|----------------------|---|--|------|--|----------|
| RELATED DOCUMENTS | | 3RD ANGLE PROJECTION | | THIS DRAWING IS CONFIDENTIAL AND THE PROPERTY OF TURCK INC. USE OF THIS DOCUMENT WITHOUT WRITTEN PERMISSION IS PROHIBITED. | | TURCK INC High Technology Sensors and Automation Controls 3000 CAMPUS DRIVE MINNEAPOLIS, MN 55441 1-800-544-7769 (763) 553-7300 (763) 553-0708 fax turck.com | |
| 1. | | | ALL DIMENSIONS DISPLAYED ON THIS DRAWING ARE FOR REFERENCE ONLY | DRFT | RDS | DATE | 09/04/12 |
| 2. | | | | APVD | A.A. | SCALE | 1=.8 |
| 3. | | UNIT OF MEASUREMENT | | | | DESCRIPTION | |
| 4. | | MILLIMETER [INCH] | | | | FKFD 4.5-*/S613 | |
| MATERIAL | | SEE SPECIFICATIONS | | CONTACT TURCK FOR MORE INFORMATION | | IDENTIFICATION NO. | |
| FINISH | | SEE SPECIFICATIONS | | DO NOT SCALE THIS DRAWING | | REV | |
| | | | | | | A | |
| A | | DRAWING RELEASE | | RDS | | 09/06/12 | |
| REV | | DESCRIPTION | | BY | | DATE | |
| | | | | ECO NO. | | FILE: 777015479 | |
| | | | | | | SHEET 1 OF 1 | |