

NOTES:

- 1) MATERIAL:
HOUSING: NYLON(IPA), GLASS FILLED, UL94V-0, COLOR: SEE CHART
TERMINALS: PHOSPHOR BRONZE
- 2) FINISH:
TERMINALS:
SELECT GOLD IN CONTACT AREA: 50 MICROINCHES (1.27 MICROMETERS) MIN.
SELECT TIN IN PC TAIL AREA: 100 MICROINCHES (2.54 MICROMETERS) MIN.,
WITH OVERALL NICKEL UNDERPLATE: 50 MICROINCHES (1.27 MICROMETERS) MIN.
- 3) PRODUCT SPECIFICATION AND PROCESSING PARAMETERS: PS-43860-003.
- 4) PACKAGING SPECIFICATION:
CONNECTOR ASSEMBLIES PACKAGED IN EXTRUDED TUBES PER MOLEX
PACKAGING SPECIFICATION PK-43860-004.
- 5) ALL UNTOLERANCED DIMENSIONS ARE SHOWN FOR REFERENCE ONLY.
- 6) CONFORMS TO FCC REGULATION PART 68.5 FOR MODULAR JACKS.
- 7) THIS PART CONFORMS TO CLASS B REQUIREMENTS OF COSMETIC
SPECIFICATION PS-45499-002.

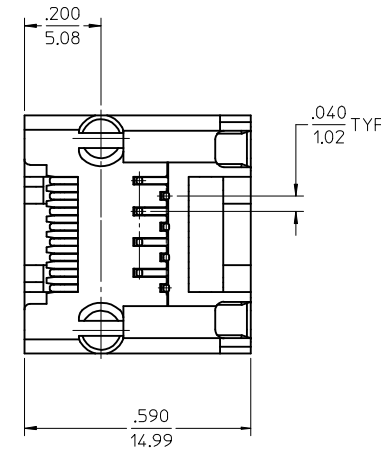
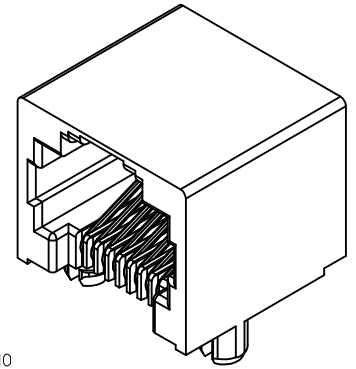
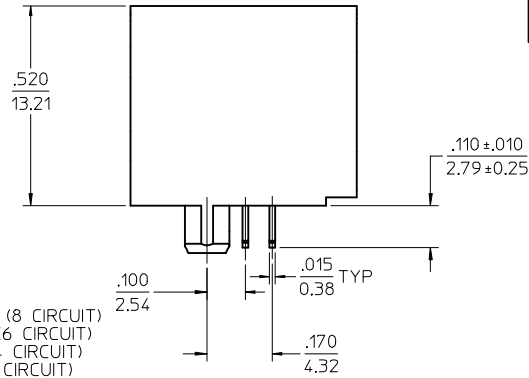
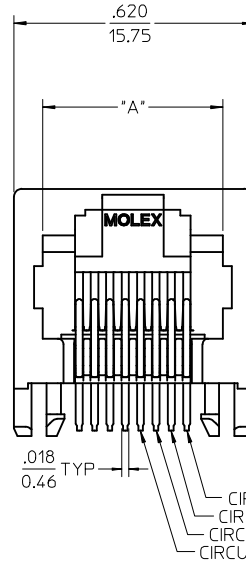
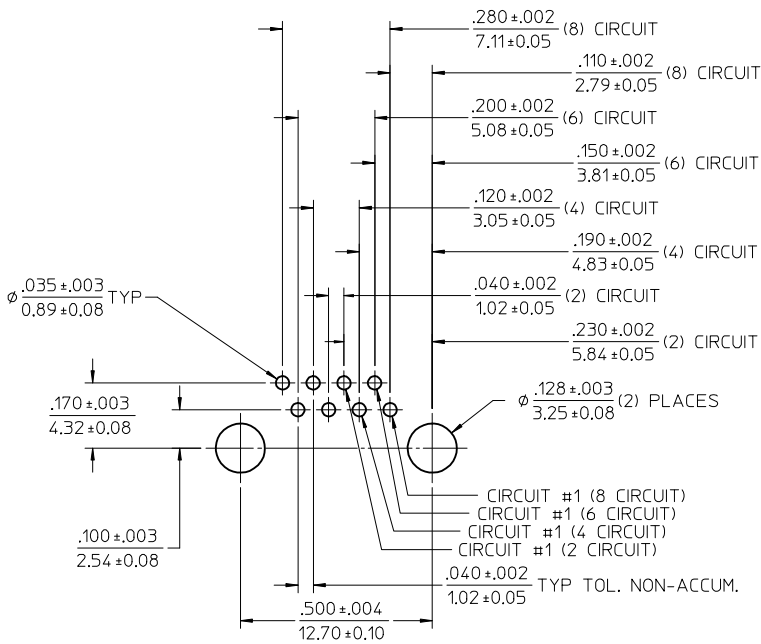

ASSEMBLY MAT. NUM.	CONNECTOR SIZE	DIM "A"	CIRCUITS	HOUSING COLOR
43860-0001	8	.469/11.91	8	BLACK
43860-0002	6	.389/9.88	6	BLACK
43860-0003	6	.389/9.88	4	BLACK
43860-0019	8	.469/11.91	4	BLACK
43860-0020	6	.389/9.88	2	BLACK

ADD -0033 EC NO: UCP2015-2348 DRAWN: NGUYEN 2014/12/08 CHKD: BELL 2014/12/08 APPR: F. SMITH 2014/12/18 REV: H8	QUALITY SYMBOLS ∇=0 ∇=0 ∇=0	GENERAL TOLERANCES (UNLESS SPECIFIED) <table border="1"> <tr> <th></th> <th>mm</th> <th>INCH</th> </tr> <tr> <td>4 PLACES ±</td> <td>---</td> <td>± .010</td> </tr> <tr> <td>3 PLACES ±</td> <td>---</td> <td>± .010</td> </tr> <tr> <td>2 PLACES ±</td> <td>0.25</td> <td>± .010</td> </tr> <tr> <td>1 PLACE ±</td> <td>---</td> <td>± .010</td> </tr> <tr> <td>0 PLACE ±</td> <td>±</td> <td>±</td> </tr> </table>		mm	INCH	4 PLACES ±	---	± .010	3 PLACES ±	---	± .010	2 PLACES ±	0.25	± .010	1 PLACE ±	---	± .010	0 PLACE ±	±	±	DIMENSION STYLE IN/MM	SCALE 4:1	DESIGN UNITS INCH	THIRD ANGLE PROJECTION
		mm	INCH																					
	4 PLACES ±	---	± .010																					
	3 PLACES ±	---	± .010																					
2 PLACES ±	0.25	± .010																						
1 PLACE ±	---	± .010																						
0 PLACE ±	±	±																						
DRAFT WHERE APPLICABLE MUST REMAIN WITHIN DIMENSIONS		MATERIAL NO. SEE CHART	DRAWN BY TALEND	DATE 1997/02/13	TITLE INVERTED MODULAR JACK ASSEMBLY																			
ANGULAR ±1/2°		DOCUMENT NO. SD-43860-001	CHECKED BY ROBERTS	DATE 1997/03/03	SHEET NO. 1 OF 5																			
APPROVED BY FRY		DATE 1997/03/04	THIS DRAWING CONTAINS INFORMATION THAT IS PROPRIETARY TO MOLEX INCORPORATED AND SHOULD NOT BE USED WITHOUT WRITTEN PERMISSION																					

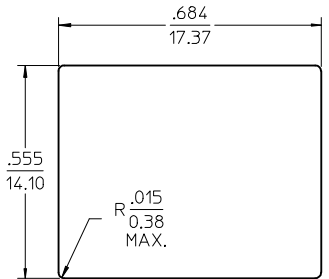
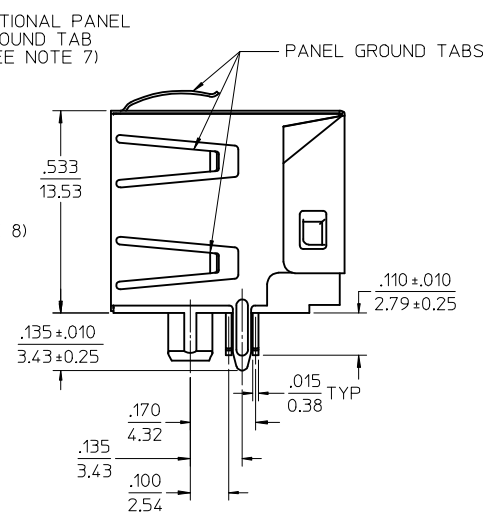
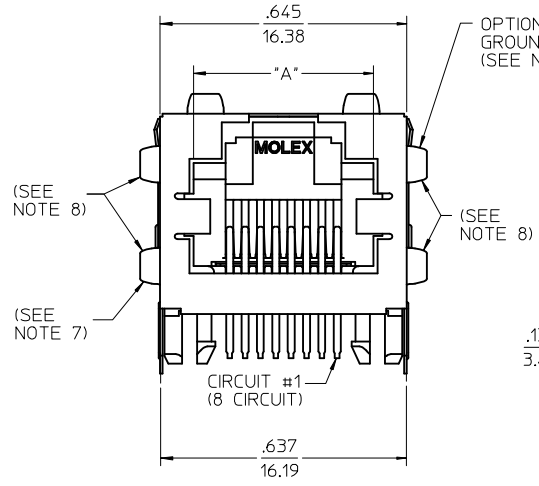
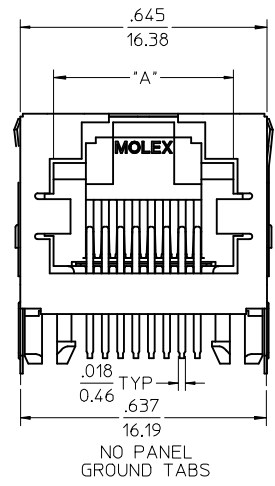
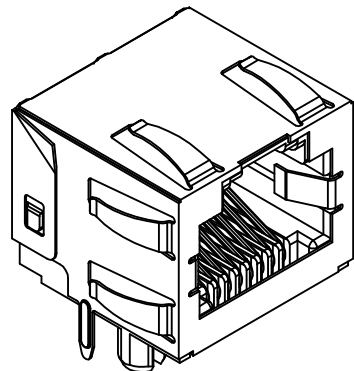

RECOMMENDED
PANEL
OPENING

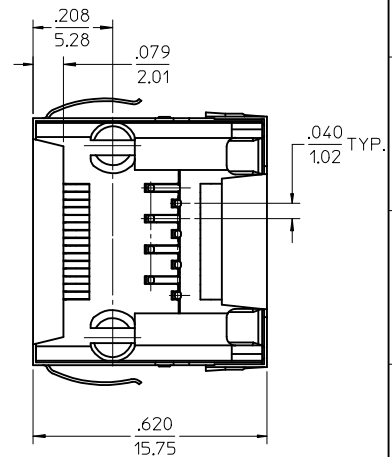
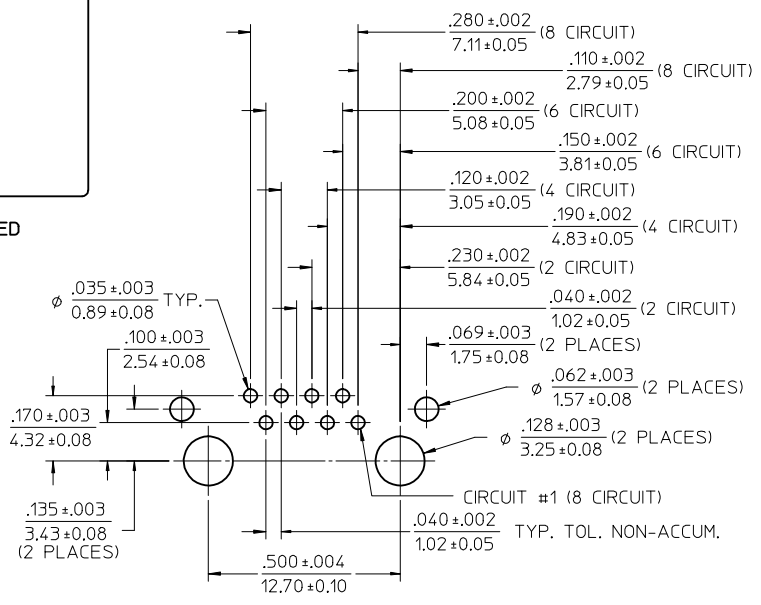

PC BOARD LAYOUT
COMPONENT SIDE OF BOARD
RECOMMENDED PCB THICKNESS .062 ±.005/1.57 ±.013

- NOTES:
1) MATERIAL:
HOUSING: NYLON(PA), GLASS FILLED, UL94V-0,
COLOR: BLACK
TERMINALS: PHOSPHOR BRONZE
SHIELD: BRASS
2) FINISH:
TERMINALS:
SELECT GOLD IN CONTACT AREA: 50 MICROINCHES/
1.27 MICROMETERS MIN.,
SELECT TIN IN PC TAIL AREA: 100 MICROINCHES/
2.54 MICROMETERS MIN.,
WITH OVERALL NICKEL UNDERPLATE: 50 MICROINCHES/
1.27 MICROMETERS MIN.
SHIELD:
100 MICROINCHES/2.54 MICROMETERS NICKEL OVER
50 MICROINCHES/1.27 MICROMETERS COPPER
UNDERPLATE, PCB GROUND TABS DIPPED IN TIN
3) PRODUCT SPECIFICATION: PS-43860-003.
4) PACKAGING SPECIFICATION:
CONNECTOR ASSEMBLIES PACKAGED IN THERMOFORMED TRAYS
PER MOLEX PACKAGING SPECIFICATION PK-43860-005,
43860-5025 CONNECTOR ASSEMBLIES PACKAGED IN TAPE AND
REEL PER MOLEX PACKAGING SPECIFICATION PK-70873-700*
5) ALL UNTOLERANCED DIMENSIONS ARE SHOWN FOR REFERENCE ONLY.
6) CONFORMS TO FCC REGULATION PART 68.5 FOR MODULAR JACKS.
7) AVAILABLE WITH THE (2) SPECIFIED PANEL GROUND TABS
OMITTED FOR SIDE TO SIDE STACKABILITY, PER THE ASSEMBLY
MATERIAL NUMBER TABLE.
8) AVAILABLE WITH TOP PANEL GROUND TABS ONLY, PER THE
ASSEMBLY MATERIAL NUMBER TABLE.
9) THIS PART CONFORMS TO CLASS B REQUIREMENTS OF COSMETIC
SPECIFICATION PS-45499-002.

ASSEMBLY MAT. NUM.	CONNECTOR SIZE	DIM "A"	CIRCUITS	PANEL GROUND TABS	PACKAGING OPTION
43860-0004	8	.469/11.91	8	ALL	TRAY
43860-0005	6	.389/9.88	6	ALL	TRAY
43860-0006	6	.389/9.88	4	ALL	TRAY
43860-0013	8	.469/11.91	8	SEE NOTE #7	TRAY
43860-0014	6	.389/9.88	6	SEE NOTE #7	TRAY
43860-0015	6	.389/9.88	4	SEE NOTE #7	TRAY
43860-0024	6	.389/9.88	2	ALL	TRAY
43860-0025	8	.469/11.91	8	NONE	TRAY
43860-0026	6	.389/9.88	6	NONE	TRAY
43860-0027	6	.389/9.88	4	NONE	TRAY
43860-0031	8	.469/11.91	8	SEE NOTE #8	TRAY
43860-0033	8	.469/11.91	8	NONE	TRAY
43860-5025	8	.469/11.91	8	NONE	TAPE

SEE SHEET 1 EC NO: UCP2015-2348 DRAWN: NGUYEN 2014/12/08 CHKD: JEBEL 2014/12/08 APPR: FSM/TH 2014/12/18	QUALITY SYMBOLS ▽=0 ▽=0 ▽=0	GENERAL TOLERANCES (UNLESS SPECIFIED)		DIMENSION STYLE IN/MM		SCALE 4:1	DESIGN UNITS INCH	THIRD ANGLE PROJECTION	
		DRAWN BY TALEND		DATE 1997/02/13		TITLE INVERTED MODULAR JACK ASSEMBLY		SHEET NO. 2 OF 5	
DRAFT WHERE APPLICABLE MUST REMAIN WITHIN DIMENSIONS		ANGULAR ±1/2°		MATERIAL NO. SEE CHART		DOCUMENT NO. SD-43860-001		THIS DRAWING CONTAINS INFORMATION THAT IS PROPRIETARY TO MOLEX INCORPORATED AND SHOULD NOT BE USED WITHOUT WRITTEN PERMISSION	

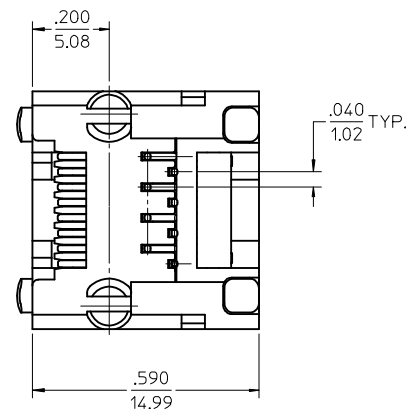
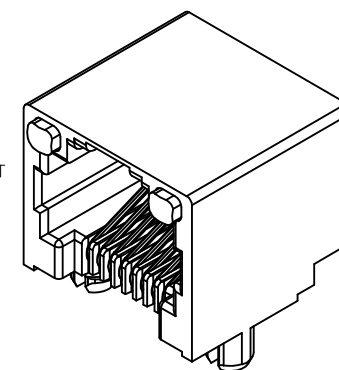
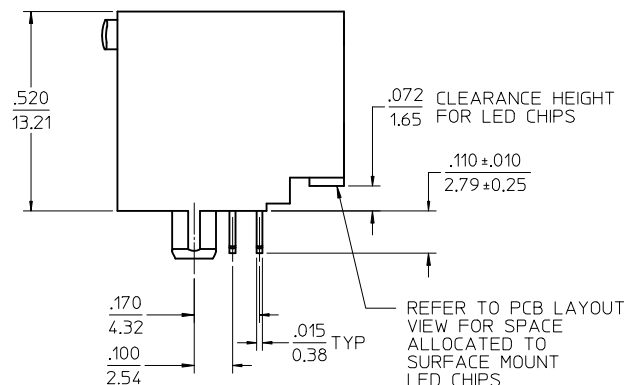
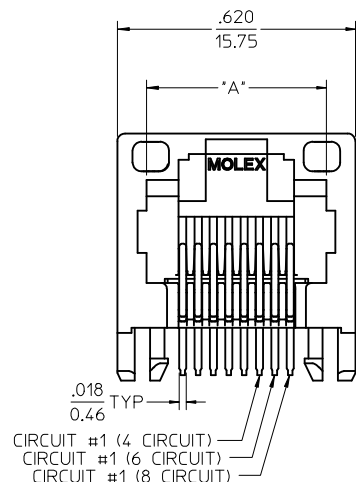

- NOTES:
- MATERIAL:
 HOUSING: NYLON(PA), GLASS FILLED, UL94V-0, COLOR: BLACK
 TERMINALS: PHOSPHOR BRONZE
 LIGHT PIPES:
 POLYCARBONATE - WAVE OR HAND SOLDER ONLY
 (NOT DESIGNED FOR I/R REFLOW OR CONVECTION REFLOW SOLDER PROCESSES)
 POLYSULFONE - MAXIMUM REFLOW TEMPERATURE 400°F (205°C)
 - FINISH:
 TERMINALS:
 SELECT GOLD IN CONTACT AREA: 50 MICROINCHES (1.27 MICROMETERS) MIN.,
 SELECT TIN IN PC TAIL AREA: 100 MICROINCHES (2.54 MICROMETERS) MIN.,
 WITH OVERALL NICKEL UNDERPLATE: 50 MICROINCHES (1.27 MICROMETERS) MIN.
 - PRODUCT SPECIFICATION AND PROCESSING PARAMETERS: PS-43860-003.
 - PACKAGING SPECIFICATION:
 CONNECTOR ASSEMBLIES PACKAGED IN EXTRUDED TUBES PER MOLEX PACKAGING SPECIFICATION PK-43860-004.
 - APPLICATION SPECIFICATION: AS-43860-001
 - ALL UNTOLERANCED DIMENSIONS ARE SHOWN FOR REFERENCE ONLY.
 - CONFORMS TO FCC REGULATION PART 68.5 FOR MODULAR JACKS.
 - REFER TO SHEET (5) OF (5) FOR RECOMMENDED PCB LAYOUT.
 - THIS PART CONFORMS TO CLASS B REQUIREMENTS OF COSMETIC SPECIFICATION PS-45499-002.

ASSEMBLY MAT. NUM.	LIGHT PIPE MATERIAL	CONNECTOR SIZE	DIM "A"	CIRCUITS
43860-0007	POLYCARBONATE	8	.469/11.91	8
43860-0008	POLYCARBONATE	6	.389/9.88	6
43860-0009	POLYCARBONATE	6	.389/9.88	4
43860-0021	POLYSULFONE	8	.469/11.91	8
43860-0022	POLYSULFONE	6	.389/9.88	6
43860-0023	POLYSULFONE	6	.389/9.88	4

REV	DESCRIPTION	QUALITY SYMBOLS	GENERAL TOLERANCES (UNLESS SPECIFIED)		DIMENSION STYLE	SCALE	DESIGN UNITS	THIRD ANGLE PROJECTION
			mm	INCH	IN/MM	4:1	INCH	
H8	SEE SHEET 1 EC NO: UCP2015-2348 DRAWN: NGUYEN 2014/12/08 CHKD: BELL 2014/12/08 APPR: F. SMITH 2014/12/18		4 PLACES ± --- ± ---	TALEND 1997/02/13	DRAWN BY DATE	TITLE INVERTED MODULAR JACK ASSEMBLY	DOCUMENT NO. SD-43860-001	SHEET NO. 3 OF 5
			3 PLACES ± --- ± .010	CHECKED BY DATE				
			2 PLACES ± 0.25 ± ---	ROBERTS 1997/03/03				
			1 PLACE ± --- ± ---	APPROVED BY DATE				
			0 PLACE ± ±	FRY 1997/03/04				
DRAFT WHERE APPLICABLE MUST REMAIN WITHIN DIMENSIONS			ANGULAR ±1/2°		MATERIAL NO.	SEE CHART		
THIS DRAWING CONTAINS INFORMATION THAT IS PROPRIETARY TO MOLEX INCORPORATED AND SHOULD NOT BE USED WITHOUT WRITTEN PERMISSION								

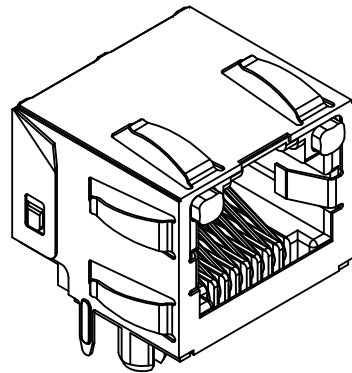

OPTIONAL PANEL GROUND TAB (SEE NOTE 8)

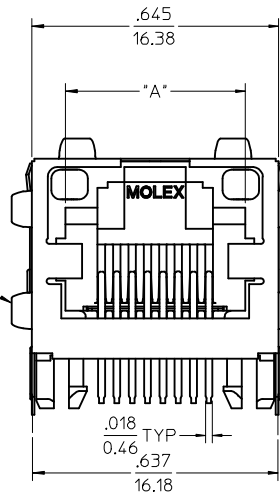

OPTIONAL PANEL GROUND TAB (SEE NOTE 8)

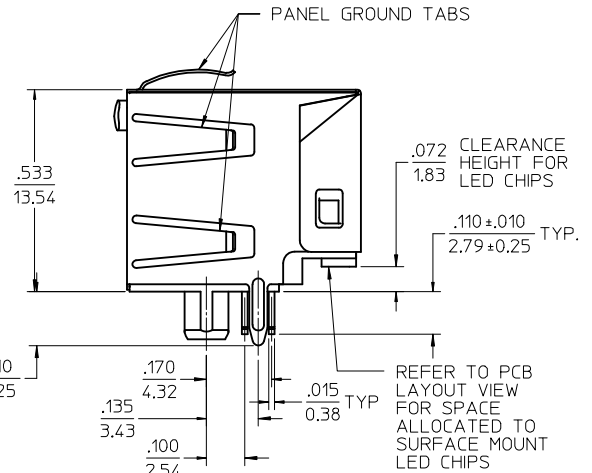

REFER TO PCB LAYOUT VIEW FOR SPACE ALLOCATED TO SURFACE MOUNT LED CHIPS

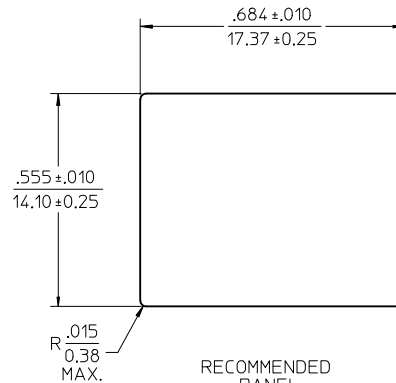

RECOMMENDED PANEL OPENING

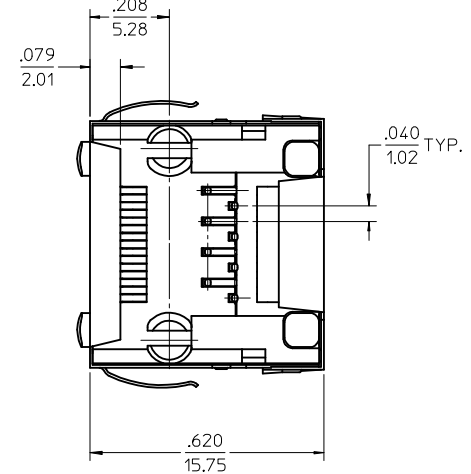

- NOTES:
- MATERIAL:
HOUSING: NYLON(PA), GLASS FILLED, UL94V-0, COLOR: BLACK
TERMINALS: PHOSPHOR BRONZE
SHIELD: BRASS
LIGHT PIPES:
POLYCARBONATE - WAVE OR HAND SOLDER ONLY (NOT DESIGNED FOR 1/2 REFLOW OR CONVECTION REFLOW SOLDER PROCESSES)
POLYSULFONE - MAXIMUM REFLOW TEMPERATURE 400°F (205°C)
 - FINISH:
TERMINALS:
SELECT GOLD IN CONTACT AREA: 50 MICROINCHES/1.27 MICROMETERS MIN.,
SELECT TIN IN PC TAIL AREA: 100 MICROINCHES/2.54 MICROMETERS MIN.,
WITH OVERALL NICKEL UNDERPLATE: 50 MICROINCHES/1.27 MICROMETERS MIN.
SHIELD:
100 MICROINCHES/2.54 MICROMETERS OVER 50 MICROINCHES/1.27 MICROMETERS COPPER UNDERPLATE, PCB GROUND TABS DIPPED IN TIN
 - PRODUCT SPECIFICATION AND PROCESSING PARAMETERS: PS-43860-003.
 - PACKAGING SPECIFICATION:
CONNECTOR ASSEMBLIES PACKAGED IN THERMOFORMED TRAYS PER MOLEX PACKAGING SPECIFICATION PK-43860-005.
 - APPLICATION SPECIFICATION: AS-43860-001
 - ALL UNTOLERANCED DIMENSIONS ARE SHOWN FOR REFERENCE ONLY.
 - CONFORMS TO FCC REGULATION PART 68.5 FOR MODULAR JACKS.
 - AVAILABLE WITH THE (2) SPECIFIED PANEL GROUND TABS OMITTED FOR SIDE TO SIDE STACKABILITY, PER THE ASSEMBLY MATERIAL NUMBER TABLE.
 - REFER TO SHEET (5) OF (5) FOR RECOMMENDED PCB LAYOUT.
 - THIS PART CONFORMS TO CLASS B REQUIREMENTS OF COSMETIC SPECIFICATION PS-45499-002.

ASSEMBLY MAT. NUM.	LIGHT PIPE MATERIAL	CONNECTOR SIZE	DIM "A"	CIRCUITS	PANEL GROUND TABS
43860-0010	POLYCARBONATE	8	.469/11.91	8	ALL
43860-0011	POLYCARBONATE	6	.389/9.88	6	ALL
43860-0012	POLYCARBONATE	6	.389/9.88	4	ALL
43860-0016	POLYCARBONATE	8	.469/11.91	8	SEE NOTE #8
43860-0017	POLYCARBONATE	6	.389/9.88	6	SEE NOTE #8
43860-0018	POLYCARBONATE	6	.389/9.88	4	SEE NOTE #8
43860-1010	POLYSULFONE	8	.469/11.91	8	ALL
43860-1011	POLYSULFONE	6	.389/9.88	6	ALL
43860-1012	POLYSULFONE	6	.389/9.88	4	ALL
43860-1016	POLYSULFONE	8	.469/11.91	8	SEE NOTE #8
43860-1017	POLYSULFONE	6	.389/9.88	6	SEE NOTE #8
43860-1018	POLYSULFONE	6	.389/9.88	4	SEE NOTE #8

SEE SHEET 1 EC NO: UCP2015-2348 DRAWN: NGUYEN 2014/12/08 CHKD: BELL 2014/12/08 APPR: F. SMITH 2014/12/18 H8	QUALITY SYMBOLS ∇=0 ∇=0 ∇=0	GENERAL TOLERANCES (UNLESS SPECIFIED) mm INCH 4 PLACES ± --- ± --- 3 PLACES ± --- ± .010 2 PLACES ± 0.25 ± --- 1 PLACE ± --- ± --- 0 PLACE ± ±	DIMENSION STYLE IN/MM DRAWN BY DATE TALEND 1997/02/13 CHECKED BY DATE ROBERTS 1997/03/03 APPROVED BY DATE FRY 1997/03/04	SCALE 4:1	DESIGN UNITS INCH	THIRD ANGLE PROJECTION
	ANGULAR ±1/2°		MATERIAL NO. SEE CHART	DOCUMENT NO. SD-43860-001	SHEET NO. 4 OF 5	INVERTED MODULAR JACK ASSEMBLY molex
	DRAFT WHERE APPLICABLE MUST REMAIN WITHIN DIMENSIONS					
	THIS DRAWING CONTAINS INFORMATION THAT IS PROPRIETARY TO MOLEX INCORPORATED AND SHOULD NOT BE USED WITHOUT WRITTEN PERMISSION					

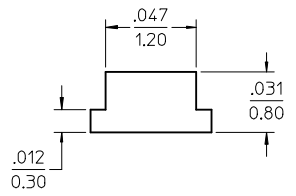
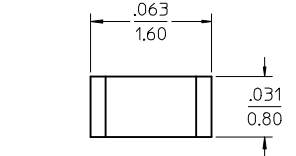
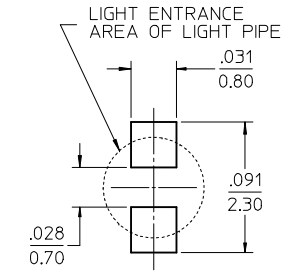
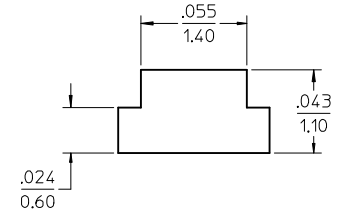
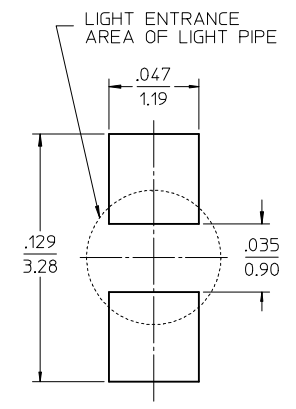
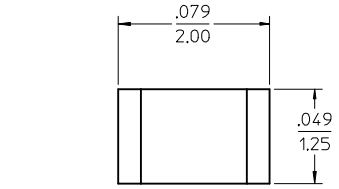
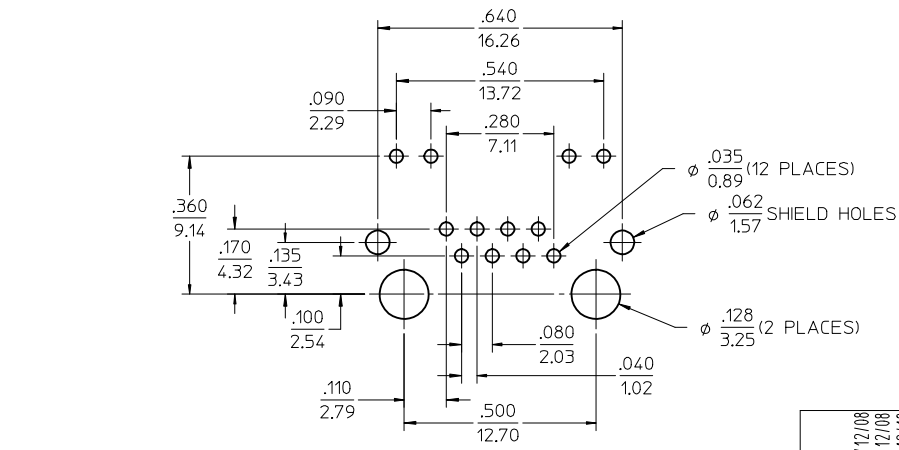
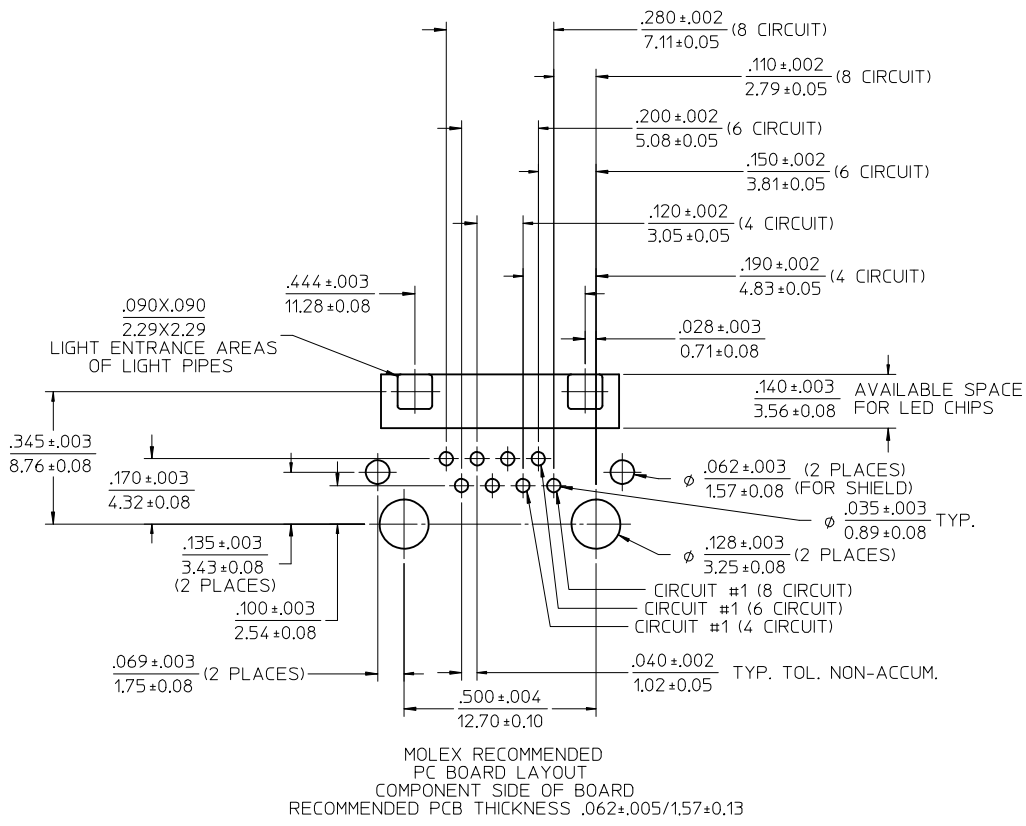

NOTES:
1. FOR CROSS REFERENCE OF RECOMMENDED LED'S SEE MOLEX WEB SITE

SEE SHEET 1 EC NO: UCP2015-2348 DRAWN: NGUYEN 2014/12/08 CHKD: BELL 2014/12/08 APPR: FSMITH 2014/12/18	QUALITY SYMBOLS ▽=0 ▽=0 ▽=0	GENERAL TOLERANCES (UNLESS SPECIFIED)	DIMENSION STYLE IN/MM	SCALE 4:1	DESIGN UNITS INCH	THIRD ANGLE PROJECTION
		4 PLACES ± --- ± ---	DRAWN BY TALEND	DATE 1997/02/13	INVERTED MODULAR JACK ASSEMBLY	
		3 PLACES ± --- ± .010	CHECKED BY ROBERTS	DATE 1997/03/03		
		2 PLACES ± 0.25 ± ---	APPROVED BY FRY	DATE 1997/03/04		
ANGULAR ±1/2°		MATERIAL NO.	DOCUMENT NO.		SHEET NO.	
DRAFT WHERE APPLICABLE MUST REMAIN WITHIN DIMENSIONS		SEE CHART	SD-43860-001		5 OF 5	
THIS DRAWING CONTAINS INFORMATION THAT IS PROPRIETARY TO MOLEX INCORPORATED AND SHOULD NOT BE USED WITHOUT WRITTEN PERMISSION						