

FIRST ANGLE PROJECTION

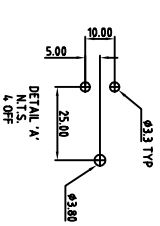
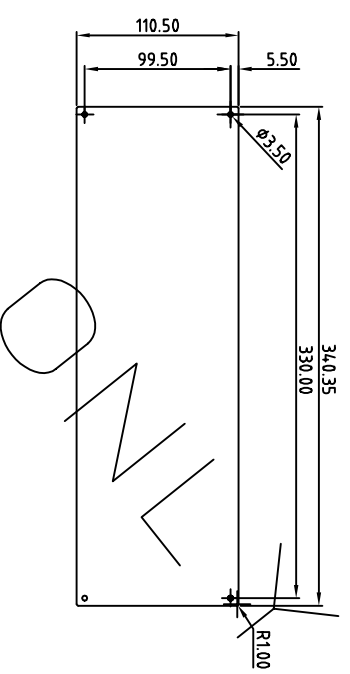
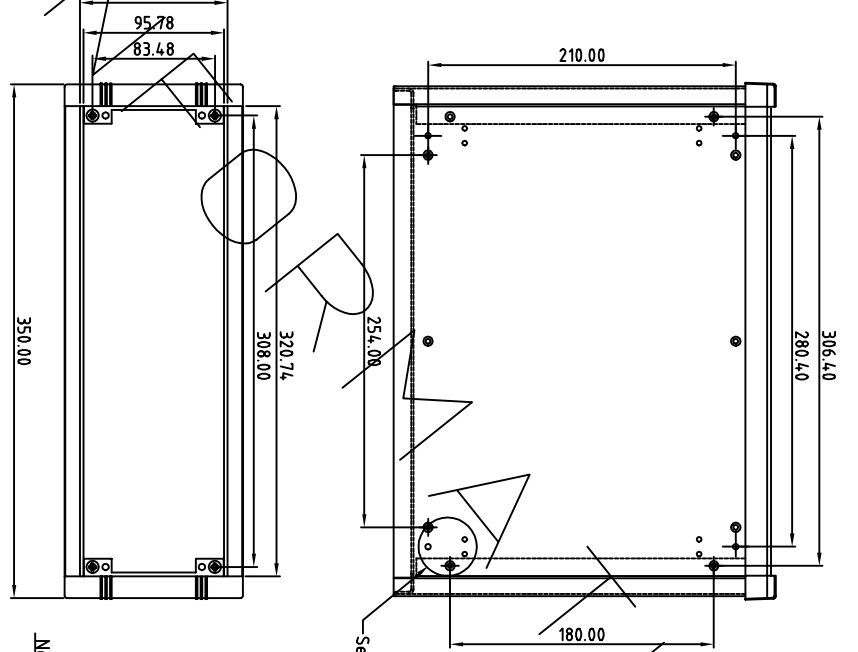
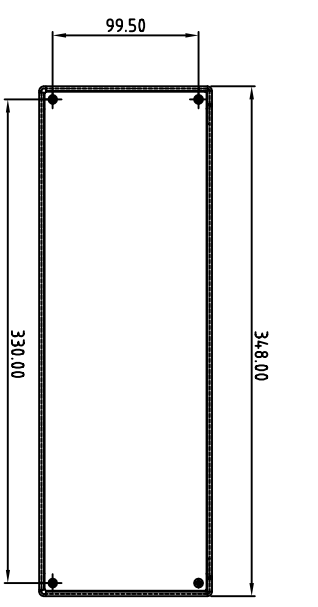
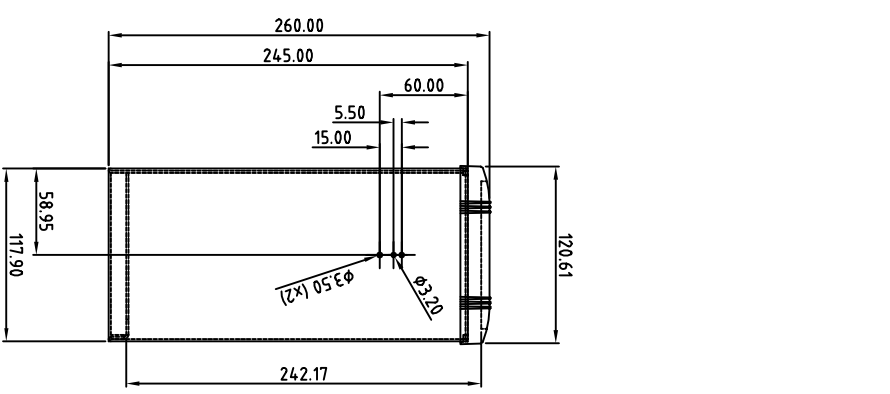

Note: Subject to technical modifications without prior notice.
 Typographical and other errors do not justify any claim for damages.
 All dimensions should be verified using the actual case.

Tolerances unless otherwise stated:

- General tolerances ± 0.20
- Resultant tolerances between hole centers ± 0.15
- Tolerances on hole diameters ± 0.05
- Angles $\pm 0.5^\circ$
- Surface finish $\sqrt{32}$

Required Finish	Scale	1:5	ALL DIMENSIONS IN MILLIMETRES	DO NOT SCALE
Drawn by:	Mark Jeffery	Checked by:		
Drawing Number	M5635215	Date drawn	19/04/01	Material Spec:
Part Name	Uninet Size 4, for Handle	Part Number	M5635215	Sheet 1 of 1
OKW ENCLOSURES LTD Unit 6, Kingdon Close, Segensworth East Farham, Hampshire, UK, PO15 5TJ		OKW ENCLOSURES LTD DATE AS SHOWN THIS DRAWING CONTAINS PROPRIETARY INFORMATION OF OKW ENCLOSURES LTD AND IS TENDERED SUBJECT TO THE FOLLOWING CONDITIONS: THE INFORMATION IS RETAINED IN CONFIDENCE, NOT BE REPRODUCED OR COPIED, AND NOT BE USED OR INCORPORATED IN ANY PRODUCT, UNLESS PERMISSION IS OBTAINED IN WRITING FROM OKW ENCLOSURES LTD.		
OKW ENCLOSURES LTD Unit 6, Kingdon Close, Segensworth East Farham, Hampshire, UK, PO15 5TJ				Sheet 1 of 1 A4

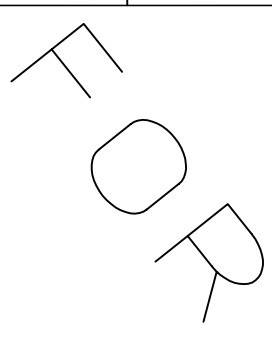

LOW

LOW