

Features

- Fast Read Access Time – 150 ns
- Automatic Page Write Operation
 - Internal Address and Data Latches for 64 Bytes
 - Internal Control Timer
- Fast Write Cycle Times
 - Page Write Cycle Time: 3 ms or 10 ms Maximum
 - 1 to 64-byte Page Write Operation
- Low Power Dissipation
 - 50 mA Active Current
 - 200 μ A CMOS Standby Current
- Hardware and Software Data Protection
- $\overline{\text{DATA}}$ Polling for End of Write Detection
- High Reliability CMOS Technology
 - Endurance: 10^4 or 10^5 Cycles
 - Data Retention: 10 Years
- Single 5V $\pm 10\%$ Supply
- CMOS and TTL Compatible Inputs and Outputs
- JEDEC Approved Byte-wide Pinout
- Full Military and Industrial Temperature Ranges
- Green (Pb/Halide-free) Packaging Option

1. Description

The AT28C256 is a high-performance electrically erasable and programmable read-only memory. Its 256K of memory is organized as 32,768 words by 8 bits. Manufactured with Atmel's advanced nonvolatile CMOS technology, the device offers access times to 150 ns with power dissipation of just 440 mW. When the device is deselected, the CMOS standby current is less than 200 μ A.

The AT28C256 is accessed like a Static RAM for the read or write cycle without the need for external components. The device contains a 64-byte page register to allow writing of up to 64 bytes simultaneously. During a write cycle, the addresses and 1 to 64 bytes of data are internally latched, freeing the address and data bus for other operations. Following the initiation of a write cycle, the device will automatically write the latched data using an internal control timer. The end of a write cycle can be detected by $\overline{\text{DATA}}$ Polling of I/O7. Once the end of a write cycle has been detected a new access for a read or write can begin.

Atmel's AT28C256 has additional features to ensure high quality and manufacturability. The device utilizes internal error correction for extended endurance and improved data retention characteristics. An optional software data protection mechanism is available to guard against inadvertent writes. The device also includes an extra 64 bytes of EEPROM for device identification or tracking.



**256K (32K x 8)
Paged Parallel
EEPROM**

AT28C256



5. DC and AC Operating Range

		AT28C256-15	AT28C256-20	AT28C256-25	AT28C256-35
Operating Temperature (Case)	Ind.	-40°C - 85°C			
	Mil.	-55°C - 125°C	-55°C - 125°C	-55°C - 125°C	-55°C - 125°C
V _{CC} Power Supply		5V ±10%	5V ±10%	5V ±10%	5V ±10%

6. Operating Modes

Mode	\overline{CE}	\overline{OE}	\overline{WE}	I/O
Read	V _{IL}	V _{IL}	V _{IH}	D _{OUT}
Write ⁽²⁾	V _{IL}	V _{IH}	V _{IL}	D _{IN}
Standby/Write Inhibit	V _{IH}	X ⁽¹⁾	X	High Z
Write Inhibit	X	X	V _{IH}	
Write Inhibit	X	V _{IL}	X	
Output Disable	X	V _{IH}	X	High Z
Chip Erase	V _{IL}	V _H ⁽³⁾	V _{IL}	High Z

Notes: 1. X can be V_{IL} or V_{IH}.

2. Refer to AC programming waveforms.

3. V_H = 12.0V ± 0.5V.

7. Absolute Maximum Ratings*

Temperature under Bias	-55°C to +125°C
Storage Temperature	-65°C to +150°C
All Input Voltages (including NC Pins) with Respect to Ground	-0.6V to +6.25V
All Output Voltages with Respect to Ground	-0.6V to V _{CC} + 0.6V
Voltage on \overline{OE} and A9 with Respect to Ground	-0.6V to +13.5V

*NOTICE: Stresses beyond those listed under “Absolute Maximum Ratings” may cause permanent damage to the device. This is a stress rating only and functional operation of the device at these or any other conditions beyond those indicated in the operational sections of this specification is not implied. Exposure to absolute maximum rating conditions for extended periods may affect device reliability

8. DC Characteristics

Symbol	Parameter	Condition	Min	Max	Units
I _{LI}	Input Load Current	V _{IN} = 0V to V _{CC} + 1V		10	μA
I _{LO}	Output Leakage Current	V _{I/O} = 0V to V _{CC}		10	μA
I _{SB1}	V _{CC} Standby Current CMOS	$\overline{CE} = V_{CC} - 0.3V$ to V _{CC} + 1V	Ind.	200	μA
			Mil.	300	μA
I _{SB2}	V _{CC} Standby Current TTL	$\overline{CE} = 2.0V$ to V _{CC} + 1V		3	mA
I _{CC}	V _{CC} Active Current	f = 5 MHz; I _{OUT} = 0 mA		50	mA
V _{IL}	Input Low Voltage			0.8	V
V _{IH}	Input High Voltage		2.0		V
V _{OL}	Output Low Voltage	I _{OL} = 2.1 mA		0.45	V
V _{OH}	Output High Voltage	I _{OH} = -400 μA	2.4		V

9. AC Read Characteristics

Symbol	Parameter	AT28C256-15		AT28C256-20		AT28C256-25		AT28C256-35		Units
		Min	Max	Min	Max	Min	Max	Min	Max	
t_{ACC}	Address to Output Delay		150		200		250		350	ns
$t_{CE}^{(1)}$	\overline{CE} to Output Delay		150		200		250		350	ns
$t_{OE}^{(2)}$	\overline{OE} to Output Delay	0	70	0	80	0	100	0	100	ns
$t_{DF}^{(3)(4)}$	\overline{CE} or \overline{OE} to Output Float	0	50	0	55	0	60	0	70	ns
t_{OH}	Output Hold from \overline{OE} , \overline{CE} or Address, whichever occurred first	0		0		0		0		ns

10. AC Read Waveforms⁽¹⁾⁽²⁾⁽³⁾⁽⁴⁾

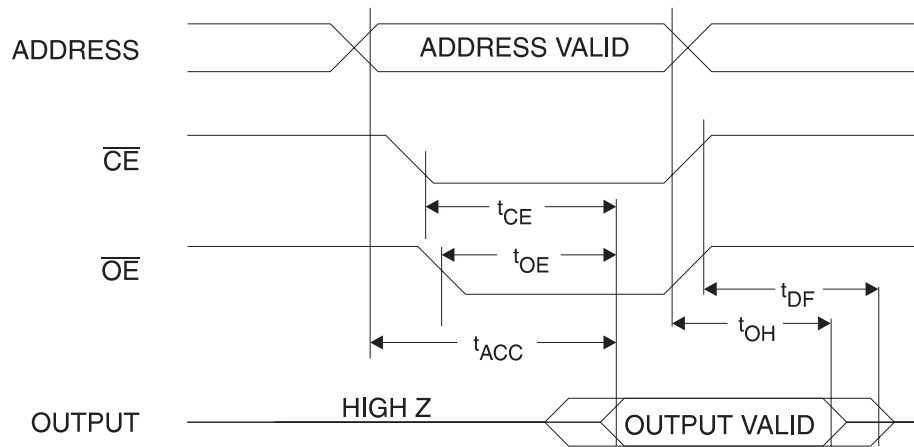

- Notes:
- \overline{CE} may be delayed up to $t_{ACC} - t_{CE}$ after the address transition without impact on t_{ACC} .
 - \overline{OE} may be delayed up to $t_{CE} - t_{OE}$ after the falling edge of \overline{CE} without impact on t_{CE} or by $t_{ACC} - t_{OE}$ after an address change without impact on t_{ACC} .
 - t_{DF} is specified from \overline{OE} or \overline{CE} whichever occurs first ($C_L = 5$ pF).
 - This parameter is characterized and is not 100% tested.

11. Input Test Waveforms and Measurement Level

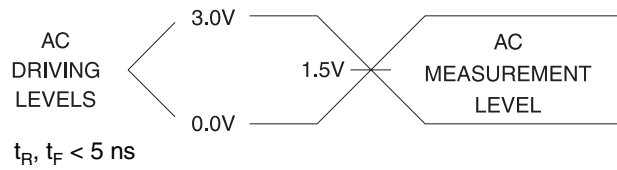

12. Output Test Load

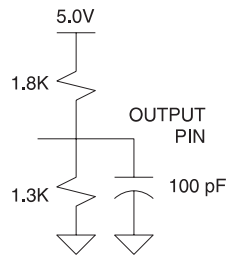

13. Pin Capacitance

f = 1 MHz, T = 25°C⁽¹⁾

Symbol	Typ	Max	Units	Conditions
C _{IN}	4	6	pF	V _{IN} = 0V
C _{OUT}	8	12	pF	V _{OUT} = 0V

Note: 1. This parameter is characterized and is not 100% tested.

14. AC Write Characteristics

Symbol	Parameter	Min	Max	Units
t_{AS}, t_{OES}	Address, \overline{OE} Setup Time	0		ns
t_{AH}	Address Hold Time	50		ns
t_{CS}	Chip Select Setup Time	0		ns
t_{CH}	Chip Select Hold Time	0		ns
t_{WP}	Write Pulse Width (\overline{WE} or \overline{CE})	100		ns
t_{DS}	Data Setup Time	50		ns
t_{DH}, t_{OEH}	Data, \overline{OE} Hold Time	0		ns
t_{DV}	Time to Data Valid	NR ⁽¹⁾		

Note: 1. NR = No Restriction

15. AC Write Waveforms

15.1 \overline{WE} Controlled

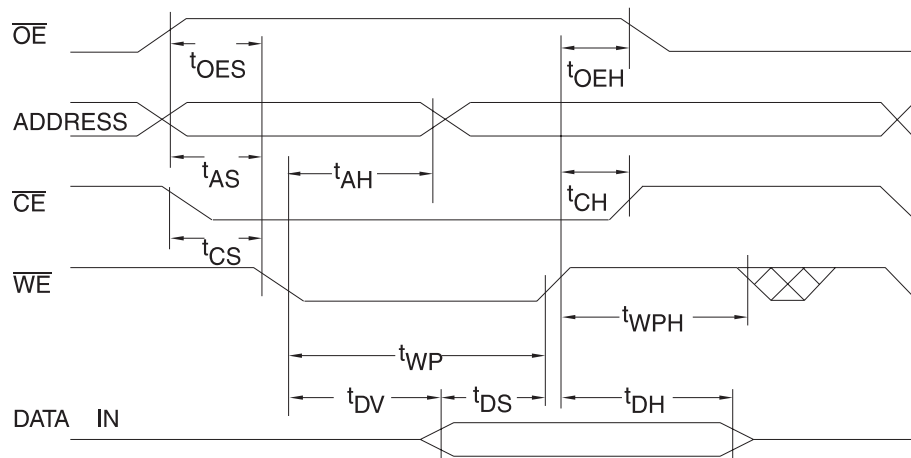

15.2 \overline{CE} Controlled

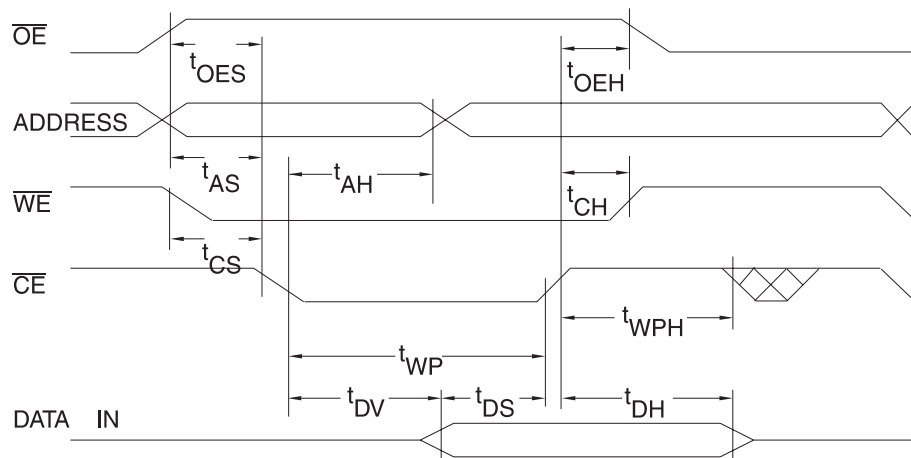

16. Page Mode Characteristics

Symbol	Parameter	Min	Max	Units
t_{WC}	Write Cycle Time (option available)	AT28C256	10	ms
		AT28C256F	3	ms
t_{AS}	Address Setup Time	0		ns
t_{AH}	Address Hold Time	50		ns
t_{DS}	Data Setup Time	50		ns
t_{DH}	Data Hold Time	0		ns
t_{WP}	Write Pulse Width	100		ns
t_{BLC}	Byte Load Cycle Time		150	μ s
t_{WPH}	Write Pulse Width High	50		ns

17. Page Mode Write Waveforms⁽¹⁾⁽²⁾

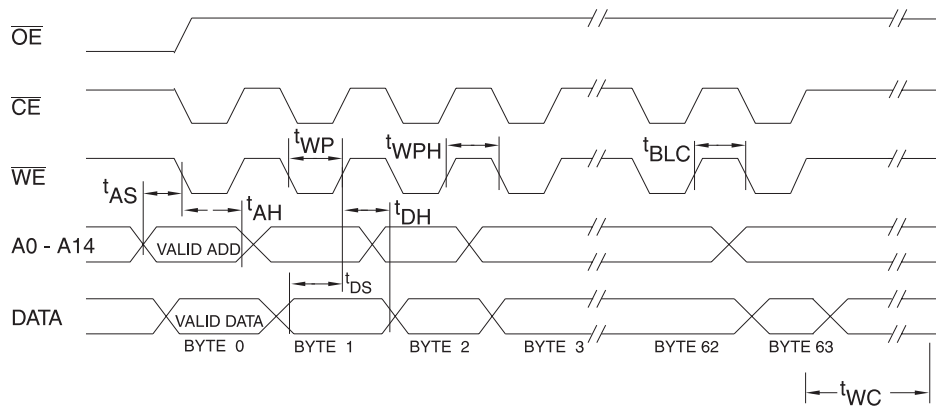

- Notes: 1. A6 through A14 must specify the same page address during each high to low transition of \overline{WE} (or \overline{CE}).
 2. \overline{OE} must be high only when \overline{WE} and \overline{CE} are both low.

18. Chip Erase Waveforms

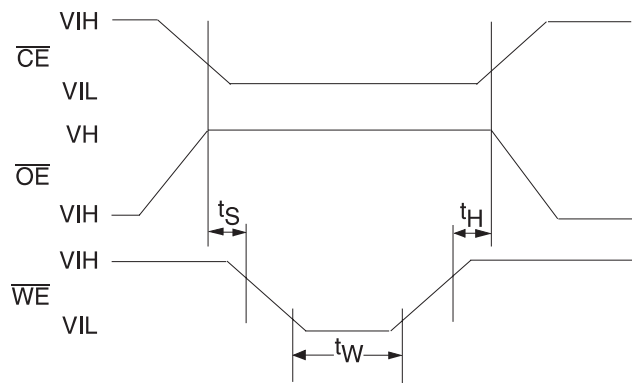

$t_S = t_H = 5 \mu\text{sec (min.)}$
 $t_W = 10 \text{ msec (min.)}$
 $V_H = 12.0V \pm 0.5V$

27.2 Green Package Option (Pb/Halide-free)

t_{ACC} (ns)	I_{CC} (mA)		Ordering Code	Package	Operation Range
	Active	Standby			
150	50	0.2	AT28C256(E, F)-15JU AT28C256(E, F)-15PU AT28C256(E, F)-15SU AT28C256(E, F)-15TU	32J 28P6 28S 28T	Industrial (-40° C to 85° C)

Package Type	
32J	32-lead, Plastic J-leaded Chip Carrier (PLCC)
28P6	28-lead, 0.600" Wide, Plastic Dual Inline Package (PDIP)
28S	28-lead, 0.300" Wide, Plastic Gull Wing Small Outline (SOIC)
28T	28-lead, Plastic Thin Small Outline Package (TSOP)
Options	
Blank	Standard Device: Endurance = 10K Write Cycles; Write Time = 10 ms
F	Fast Write Option: Write Time = 3 ms

29.5 28P6 – PDIP

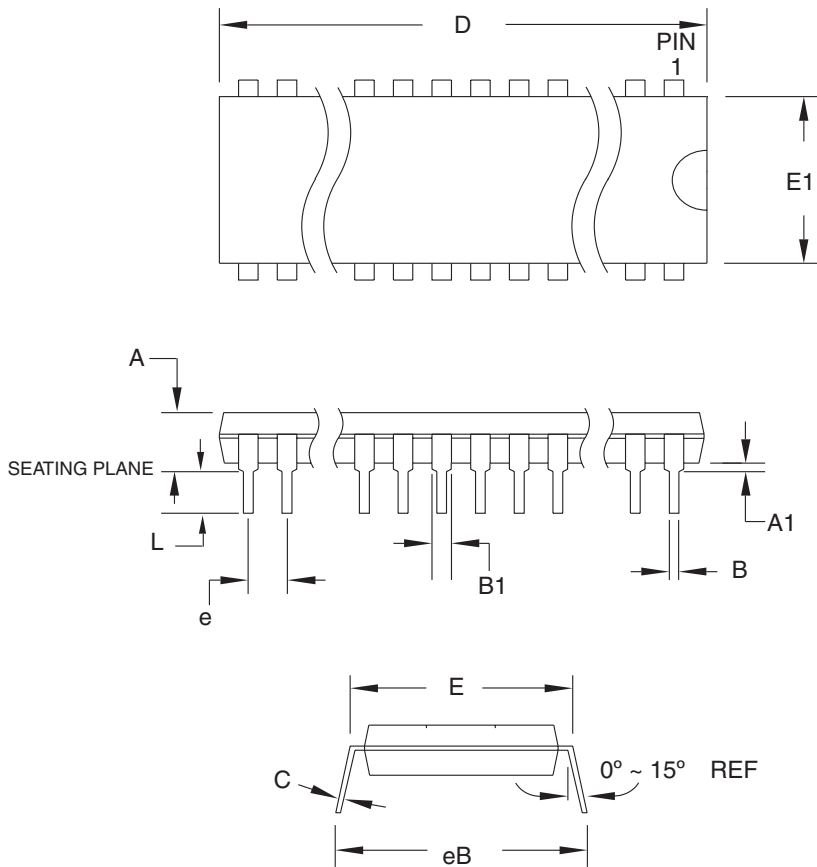

COMMON DIMENSIONS
(Unit of Measure = mm)

SYMBOL	MIN	NOM	MAX	NOTE
A	–	–	4.826	
A1	0.381	–	–	
D	36.703	–	37.338	Note 2
E	15.240	–	15.875	
E1	13.462	–	13.970	Note 2
B	0.356	–	0.559	
B1	1.041	–	1.651	
L	3.048	–	3.556	
C	0.203	–	0.381	
eB	15.494	–	17.526	
e	2.540 TYP			

- Notes:
1. This package conforms to JEDEC reference MS-011, Variation AB.
 2. Dimensions D and E1 do not include mold Flash or Protrusion. Mold Flash or Protrusion shall not exceed 0.25 mm (0.010").



2325 Orchard Parkway
San Jose, CA 95131

TITLE

28P6, 28-lead (0.600"/15.24 mm Wide) Plastic Dual
Inline Package (PDIP)

DRAWING NO.

28P6

REV.

B

